



GarrettCom™

Magnum DX900

Industrial Router

Installation Guide

GarrettCom, Incorporated
25 Commerce Way #1
North Andover, MA 01845
Phone: 978.688.8807
Fax: 978.688.8771

Declarations

DOCUMENT NOTICE

Copyright

Copyright 2007 by GarrettCom. Printed in the US. All rights reserved.

This manual may not be reproduced or disclosed in whole or in part by any means without the written consent of GarrettCom. DynaStar is a trademark of Garrett. All other trademarks mentioned in this document are the property of their respective owners.

This document has been prepared to assist users of equipment manufactured by GarrettCom and changes are made periodically to the information in this manual. Such changes are published in Software Release Notices. If you have recently upgraded your software, carefully note those areas where new commands or procedures have been added. The material contained in this manual is supplied without any warranty of any kind. GarrettCom therefore assumes no responsibility and shall incur no liability arising from the supplying or use of this document or the material contained in it.

Rights

Except as set forth in the Software License Agreement, GarrettCom makes no representation that software programs and practices described herein will not infringe on existing or future patent rights, copyrights, trademarks, trade secrets or other proprietary rights of third parties and GarrettCom makes no warranties of any kind, either express or implied, and expressly disclaims any such warranties, including but not limited to any implied warranties of merchantability or fitness for a particular purpose and any warranties of non-infringement. The descriptions contained herein do not imply the granting of licenses to make, use, sell, license or otherwise transfer GarrettCom products described herein. GarrettCom disclaims responsibility for errors which may appear in this document, and it reserves the right, in its sole discretion and without notice, to make substitutions and modifications in the products and practices described in this document.

Part Number Information

Paper Version Part Number: 3-01-2123-00 Rev. AA

CD Part Number: 3-01-2115-00

Revision History

Release Date	Document Revision	Software Release	Change Note
August, 2007	AA	1.3.4	Initial release.

WARRANTY

GarrettCom warrants equipment manufactured by it to be free from defects in materials and workmanship for a period of one (1) year from date of shipment. If within the warranty period the purchaser discovers such item was not as warranted above and promptly notifies GarrettCom in writing, GarrettCom shall repair or replace the items at the company's option. This warranty shall not apply to: (a) equipment not manufactured by GarrettCom; (b) equipment which shall have been repaired or altered by anyone other than GarrettCom; (c) equipment which shall have been subjected to negligence, accident, or damage by circumstances beyond GarrettCom control, or to improper operation, maintenance or storage, or to other than normal use or service. With respect to equipment sold but not manufactured by GarrettCom, the warranty obligation of GarrettCom shall, in all aspects, conform and be limited to the warranty actually extended to GarrettCom by its supplier.

The foregoing warranties do not cover reimbursement for labor, transportation, removal, installation, or other expenses that may be incurred in connection with repair or replacement.

THE FOREGOING WARRANTIES ARE EXCLUSIVE AND IN LIEU OF ALL OTHER EXPRESS AND IMPLIED WARRANTIES EXCEPT WARRANTIES OF TITLE, INCLUDING, BUT NOT LIMITED TO, IMPLIED WARRANTIES OF MERCHANTABILITY AND FITNESS FOR A PARTICULAR PURPOSE.

LIMITATION OF LIABILITY

Anything to the contrary herein contained notwithstanding, **GarrettCom, ITS CONTRACTORS AND SUPPLIERS OF ANY TIER, SHALL NOT BE LIABLE IN CONTRACT, IN TORT (INCLUDING NEGLIGENCE OR STRICT LIABILITY) OR OTHERWISE FOR ANY SPECIAL, INDIRECT, INCIDENTAL OR CONSEQUENTIAL DAMAGES WHATSOEVER.** The remedies of the purchaser set forth herein are exclusive where so stated and the total cumulative liability of GarrettCom its contractors and suppliers of any tier, with respect to this contract or anything done in connection therewith, such as the use of any product covered by or furnished under the contract, whether in contract, in tort (including negligence or strict liability) or otherwise, shall not exceed the price of the product or part on which such liability is based.

Unless otherwise agreed to in writing by an authorized official of GarrettCom, products sold hereunder are not intended for use in or in connection with a nuclear facility or activity. If so used, GarrettCom disclaims all liability for nuclear damage, injury or contamination, and purchaser shall indemnify GarrettCom against any such liability, whether as a result of breach of contract, warranty, tort (including negligence) or otherwise.

PATENTS

As to equipment proposed and furnished by GarrettCom, GarrettCom shall defend any suit or proceeding brought against purchaser so far as based on a claim that said equipment constitutes an infringement of any patent of the United States, if notified promptly in writing and given authority, information, and assistance at GarrettCom's expense for the defense of the claim. In event of a final award of costs and damages from such a suit, GarrettCom shall pay such award. In event the use of said equipment by purchaser is enjoined in such a suit, GarrettCom shall, at its own expense, and at its sole option either (a) procure for purchaser the right to

continue using equipment, (b) modify said equipment to render it non-infringing, (c) replace said equipment with non-infringing equipment, or (d) refund the purchase price (less depreciation) and transportation and installation costs of said equipment. GarrettCom will not be responsible for any compromise or settlement made without its written consent. The foregoing states the entire liability of GarrettCom for patent infringement, and in no event shall GarrettCom be liable if the infringement charge is based on the use of GarrettCom equipment for a purpose other than that for which it was sold by GarrettCom As to any equipment furnished by GarrettCom to purchaser and manufactured in accordance with designs proposed by purchaser, purchaser shall indemnify GarrettCom against any award made against GarrettCom for patent, trademark, or copyright infringement.

RETURN OF EQUIPMENT

No equipment may be returned without purchaser first obtaining GarrettCom's written Return Material Authorization (RMA). An RMA can be obtained by contacting Sales at 978.688-8807.

Equipment accepted for credit, not involving a GarrettCom error, shall be subject to all the terms of the original purchase contract and to a service charge. Returned equipment must be of current manufacture, unused, and in reasonable condition, securely packed to reach GarrettCom without damage, shipped F.O.B. GarrettCom facility with transportation charges paid, and labeled with Return Material Authorization (RMA) number. Any cost incurred by GarrettCom to put equipment in first class condition will be charged to purchaser.

COMPLIANCE NOTICES

FCC Part 15

This device complies with part 15 of the FCC Rules. Operation is subject to the following two conditions: (1) This device may not cause harmful interference, and (2) this device must accept any interference received, including interference that may cause undesired operation.

Note: This equipment has been tested and found to comply with the limits for a Class A digital device, pursuant to part 15 of the FCC Rules. These limits are designed to provide reasonable protection against harmful interference when the equipment is operated in a commercial environment. This equipment generates, uses and can radiate radio frequency energy and, if not installed and used in accordance with the instruction manual, may cause harmful interference to radio communications. Operation of this equipment in a residential area is likely to cause harmful interference in which case the user will be required to correct the interference at his/her own expense.

In order to maintain compliance with FCC regulations shielded cables must be used for electrical I/O with this equipment. Operation with non-approved equipment or unshielded cables may result in interference to radio and television reception.

Changes or modifications could void the user's authority to operate the equipment. The user is cautioned not to change or modify this product.

FCC Part 68

This device complies with part 68 of the FCC rules and the requirements adopted by the ACTA. On the bottom of this equipment is a label that contains, among other information, a product identifier in the format US:AAAEQ##TXXXX. If requested, this number must be provided to the telephone company.

Note: REN (Ringer Equivalence Number) does not apply to this equipment.

IC CS03 (Industry Canada)

This digital apparatus does not exceed the Class A limits for radio noise emissions from digital apparatus set out in the interference-causing equipment entitled “Digital Apparatus”, ICES-003 of the department of Communications (Cet appareil numérique respecte les limites bruits radioélectriques applicables aux appareils numériques de Class A prescrites dans la norme sur le matériel brouilleur: “Appareils Numériques”, NMB-003 édictée par le ministre des Communications).

This product meets the applicable Industry Canada technical specifications/Le présent matériel est conforme aux spécifications techniques applicables d’Industrie Canada.

EN55022

Warning: This is a Class A product. In a domestic environment this product may cause radio interference, in which case the user may be required to take adequate measures.

SAFETY

WARNING: Service to this unit can be made only by factory authorized personnel. Failure to observe this caution can result in malfunction to the unit as well as electrocution to personnel.

Avertissement: Cet appareil ne peut être examiné ou réparé que par un employé autorisé du fabricant. Si cette consigne n’est pas respectée, il y a risque de panne et d’électrocution.

Vorsicht: Dieses Gerät darf nur durch das bevollmächtigte Kundendienstpersonal der fabrik instandgehalten werden. Die Nichtbeachtung dieser Vorschrift kann zu Fehlfunktionen des Gerätes führen und das Personal durch Stromschläge gefährden.

Industry Canada Warnings	Avis d’Industrie Canada
<p>Notice:</p> <p>Before installing this equipment, users should ensure that it is permissible to be connected to the facilities of the local telecommunications company. The equipment must also be installed using an acceptable method of connection. The customer should be aware that compliance with the above conditions may not prevent degradation of service in some situations.</p> <p>Repairs to certified equipment should be coordinated by a representative designated by the supplier. Any repairs or alterations made by the user to this equipment, or equipment malfunctions, may give the telecommunications company cause to request the user to disconnect the equipment.</p>	<p>Avis:</p> <p>Avant d’installer ce matériel, l’utilisateur doit s’assurer qu’il est permis de le raccorder aux installations de l’entreprise locale de télécommunication. Le matériel doit également être installé en suivant une méthode acceptée de raccordement. L’abonné ne doit pas oublier qu’il est possible que la conformité aux conditions énoncées ci-dessus n’empêche pas la dégradation du service dans certaines situations.</p> <p>Les réparations de matériel homologué doivent être coordonnées par un représentant désigné par le fournisseur. L’entreprise de télécommunications peut demander à l’utilisateur de débrancher un appareil à la suite de réparations ou de modifications effectuées par l’utilisateur ou à cause de mauvais fonctionnement.</p>
<p>Users should ensure for their own protection that the electrical ground connections of the power utility, telephone lines, and internal metallic water pipe system, if present, are connected together. The precaution may be particularly important in rural areas.</p>	<p>Pour sa propre protection, l’utilisateur doit s’assurer que tous les fils de mise à la terre de la source d’énergie électrique, des lignes téléphoniques et des canalisations d’eau métalliques, s’il y en a, sont raccordés ensemble. Cette précaution est particulièrement importante dans les régions rurales.</p>

Service Personnel Warning

The DX devices may be AC or DC powered. Remove all power connections at the circuit panel before removing the unit.

The installation of this product must comply with all applicable codes and practices specified by the country, city, and operating company in which it is installed.

Grounding

All units requiring grounding. Use a grounding wire with a minimum size of 14 AWG at a maximum length of five feet.

The DX900 is equipped with an external grounding bolt (#10/32 UNF-2B). The ground lug bolt should be torqued to 32 inch pounds (3.6 Nm).

CONTACTING GARRETTCOM

By Mail:

GarrettCom
25 Commerce Way #1
North Andover, MA 01845

Telephone:

978.688-8807

Fax:

978.688-8771

Website:

www.garrettcom.com

Email:

support@garrettcom.com

Customer support representatives are available during normal business hours, 8 - 5pm EST.

TABLE OF CONTENTS

Preface

About This Manual	ix
Conventions	ix
Related Documents	ix
Web Access	x
Your Comments	x

CHAPTER 1: OVERVIEW

1.1 Overview	1
1.2 Configuration	1
1.2.1 Connectivity	1
1.2.2 Power and Ground	2
1.2.3 Indicators	2
1.2.4 Mounting Options	3
1.3 Specifications	4
1.3.1 Physical	4
1.3.2 Environmental	4
1.3.3 Compliance	5
1.3.4 Power Requirements	5
1.3.5 Ports and External Connectors	6
1.3.6 Indicators	6
1.4 Pinouts	7
1.4.1 RJ48	7
1.4.2 RJ45	8
1.4.3 DB9 (Female) – RS232 Serial Ports and Console Port	8
1.4.4 DB9 (Female) – Alarm Port	9
1.4.5 DB9 (Female) – RS485 Serial Ports	9

CHAPTER 2: INSTALLATION

2.1 Preparing for Installation	11
2.1.1 Tools	11
2.1.2 Site Suitability	11
2.1.3 Wiring and Grounding Guidelines	12
2.1.4 External Connections	12
2.2 Unpacking	12
2.3 Installation of the DX900 Unit	13
2.3.1 Mounting	13
2.3.1.1 Mounting in a 19" Rail System	13
2.3.1.2 Mounting on a Panel	14
2.3.1.3 Mounting in a DIN Rail System	15
2.3.2 Connecting Facility Power	17
2.3.2.1 Making the Ground and Power Connections	17

CONTENTS

2.3.3	Connecting to the Console Port and the Alarm Port	18
2.3.3.1	Console Port	18
2.3.3.2	Alarm Port	18
2.3.4	Connecting Network Cables	19
2.3.4.1	Connecting Serial Cables	19
2.3.4.2	Connecting Ethernet Copper Cables	19
2.3.4.3	Connecting the WAN Cable	19
2.4	Maintenance	20
2.4.1	Removing the DX900	20
2.4.1.1	Disconnecting Network Cables	20
2.4.1.2	Disconnecting Power and Ground Lines	20
2.4.1.3	Packing the DX900 for Shipment	21

Preface

ABOUT THIS MANUAL

This document provides instructions for installing the Magnum DX900 hardware. This document gives product descriptions, specifications, detailed information on ports and pinouts, all site preparation required to install the product, complete installation procedures, power up instructions, and instructions for removing and maintaining the product. This document is arranged as follows:

Chapter 1, “Overview” - Contains a brief product description, a list of applicable specifications, and a description of all controls and indicators and pinouts for connectors.

Chapter 2, “Installation” - Contains all site preparation that must be accomplished prior to installing the DX900, installation in a rack, panel, or DIN rail system, powering the unit up, and making all external connections. This chapter also includes maintenance procedures.

CONVENTIONS

Graphically distinctive alerts labeled either “Note” or “Caution” (illustrated below) are interspersed throughout this manual. These alerts call your attention to useful information related to the text immediately following the alert. Notes provide supplemental information or provide a point of emphasis. Cautions warn you of the risk of poor system performance or of system failure.



NOTE: Notes provide you with helpful information about an upcoming step or action. If you do not use the information contained in a Note there is no risk of harm to the system, but using the information will improve performance and/or increase your understanding.



CAUTION: A caution warns you that you should take some action to avoid poor system performance or system failure.



LASER WARNING: This Warning is used to call attention to the fact that Laser output can cause serious damage to the eye.



ELECTRICAL WARNING: This format is used for Electrical Warnings. Callouts of this format are used to notify that a potential of electrocution exists and that a defined action could cause personal injury or death to occur.

RELATED DOCUMENTS

- *Magnum Network Software – DX Administrator’s Guide*

WEB ACCESS

All of the DX900 manuals are also available in .pdf format on the GarrettCom website, www.garrettcom.com.

YOUR COMMENTS

If you find an error or have a helpful tip on the layout or informational content of this or any other GarrettCom manual please feel free to contact us via email with any problems or helpful information. All enquiries will be responded to with a correction or whatever resolution is required. Please make all comments to support@garrettcom.com or phone a support engineer at 978.688-8807.

Chapter 1

Overview

1.1 Overview

The Magnum DX900 provides connectivity to asynchronous and Ethernet traffic through four programmable serial ports, four 10/100 BaseT Ethernet ports for copper line connections, and one DDS or T1/E1 WAN port.

1.2 Configuration

The following sections describe the features and requirements of the DX900.

1.2.1 Connectivity

The DX900 is equipped with:

- 1 DDS or T1/E1 WAN port
- 4 ethernet ports 10/100 BaseT, RJ45
- 4 serial programmable RS232/485 ports

These ports are all located on the front face of the device, along with the MAC address, as illustrated in [Figure 1-1](#).

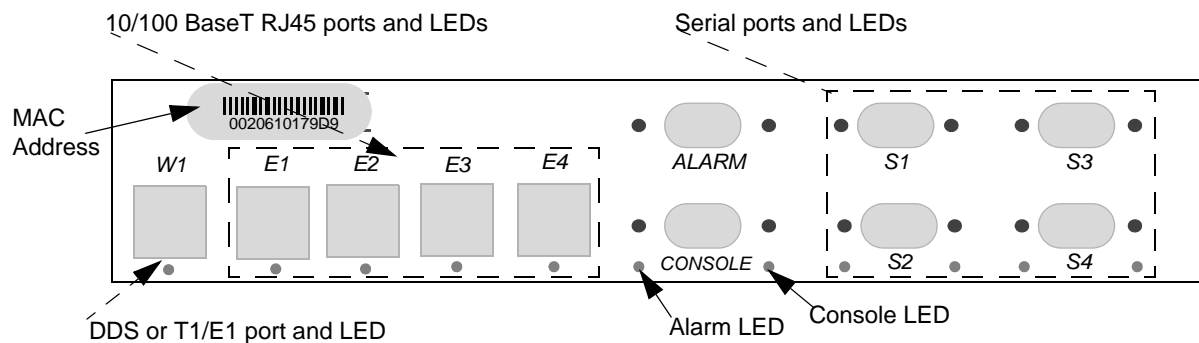

Figure 1-1. Front View

1.2.2 Power and Ground

The DX900 can be ordered with a high (90 -250 VAC or VDC) or Low (24-48 VDC) voltage power supply. The connection point for the power supply is located at the rear of the chassis. The rear face also contains the primary ground stud and labels including serial number, model number, and port and power specifications, as illustrated in [Figure 1-2](#).

For detailed power specifications see [Table 1-4](#).

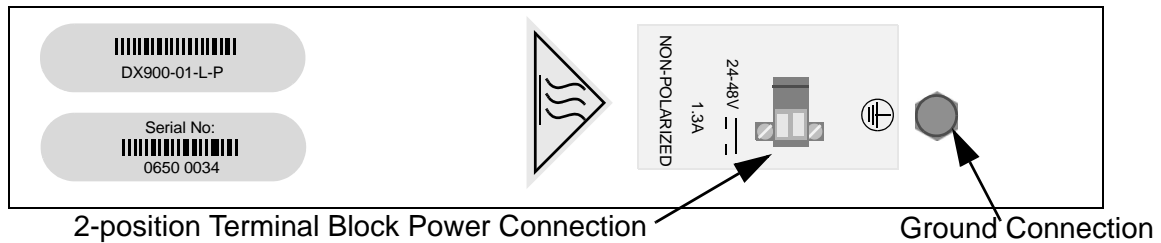



Figure 1-2. Rear View



NOTE: The hot surfaces warning label () is affixed to this device because the device is rated to operate at **ambient** temperatures as high as 85C (185F). Clearly, if the device were to be installed in an environment in which temperatures at the upper end of its operating range were attained, the metal surfaces of the device would become too hot to touch.

1.2.3 Indicators

The operational status of the ports of the DX900 is indicated by LEDs located near the physical ports on the front of the DX900, as illustrated in [Figure 1-1](#), and a bank of LEDs on the top of the chassis, as illustrated in [Figure 1-3](#).

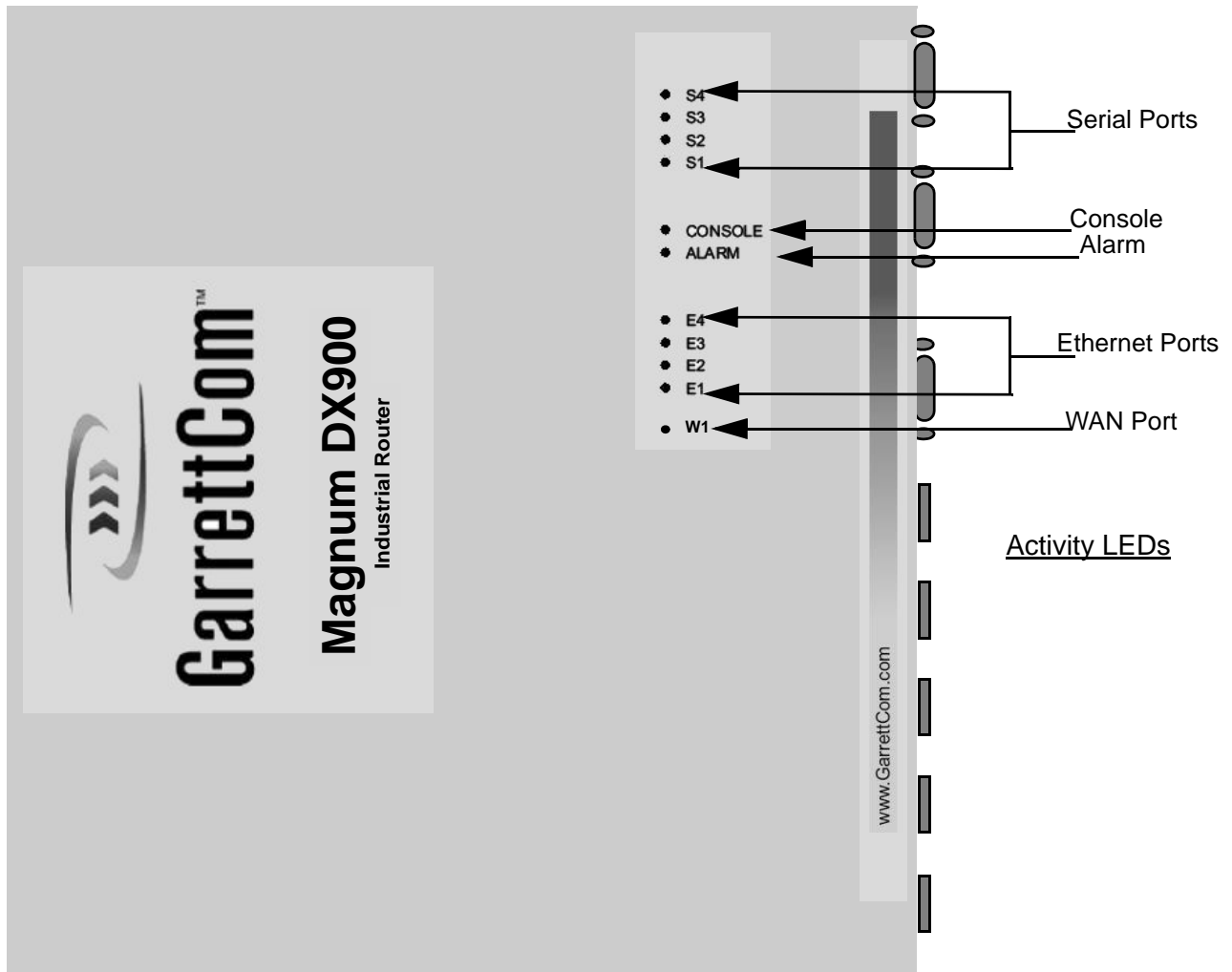

Figure 1-3. Top View

1.2.4 Mounting Options

There are three mounting options for the DX900:

- 19" rack mount (see [Section 2.3.1.1](#))
- Panel mount (see [Section 2.3.1.2](#))
- DIN rail mount (see [Section 2.3.1.3](#))

Each of these options requires specific accessory hardware. Each type of accessory hardware mates up with a specific set of screw holes on the sides of the chassis, illustrated in [Figure 1-4](#).

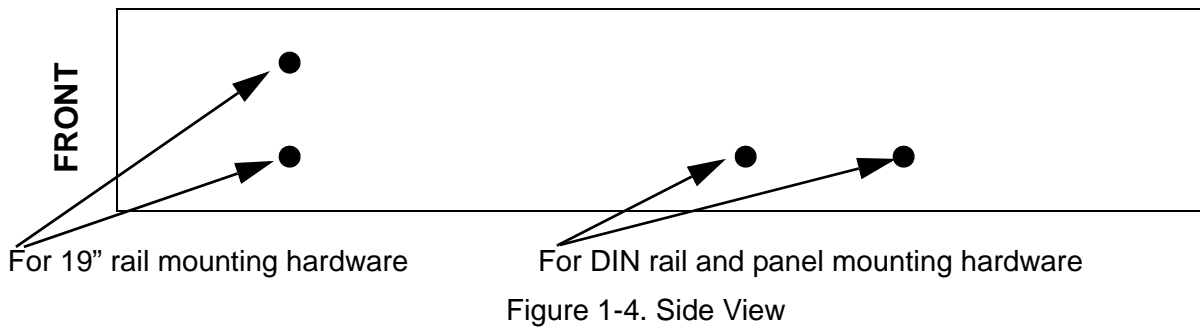

1.3 Specifications

The following sections provide detailed information about the physical, electronic, and industrial specifications of the DX900.

1.3.1 Physical

The physical dimensions and weight of the DX900 are defined in [Table 1-1](#).

Table 1-1. Physical Specifications

Height:	1.75 inches (4.45 cm)
Width:	9.5 inches (24.13 cm)
Depth:	9.5 inches (24.13 cm)
Weight:	5.0 lbs (2.3 kg)

1.3.2 Environmental

The environmental specifications of the DX900 are defined in [Table 1-2](#).

Table 1-2. Environmental Specifications

Operating Temperature:	-40C to 85C (-40F to 185F) -40 to +80C (-40F to 176F. IAW 60950-1, installations in restricted access locations.) No fans
Storage Temperature:	-40C to 85C (-40F to 185F)
Operating Humidity:	95% non-condensing

1.3.3 Compliance

The industry compliance profile of the DX900 is defined in table [Table 1-3](#).

Table 1-3. Compliance With Standards

Industrial:	IEEE 1613, IEC 61850-3	
Emissions:	EN55022A, FCC Part 15A	
Immunity:	EN55024 EN61000-6-2 EN61000-6-5 EN61000-4-2 (ESD) EN61000-4-3 (RF) EN61000-4-4 (EFT) EN61000-4-5 (SURGE)	EN61000-4-6 (CRF) EN61000-4-10 (MagField) EN61000-4-11 (VDI) EN61000-4-12 (Oscillatory) EN61000-4-16 (CCM) EN61000-4-17 (Ripple) EN61000-4-29 (VDI)
Safety	UL60950, EN60950	

1.3.4 Power Requirements

The power requirements of the DX900 are defined in [Table 1-4](#).

Table 1-4. Power Requirements

	High Voltage AC/DC	Low Voltage DC
Voltage Input Range:	90-250 VAC/VDC	24-48 VDC
Max. Power (Watts):	27	27
Typical Power (Watts):	10	10
Max. Amperage (Amps):	0.3	1.3

1.3.5 Ports and External Connectors

The ports and external connectors of the DX900 are defined in [Table 1-5](#).

Table 1-5. Ports and External Connectors

Port Name	Connector	Description
WAN, W1	RJ48	<ul style="list-style-type: none"> • DDS – 56/64 Kbps DDS CSU/DSU WAN connection. • T1/E1 – CSU/DSU WAN connection.
Ethernet, E3 – E4	RJ45	10/100 Mbps Ethernet port for connection to copper Ethernet capable devices.
Serial, S1 through S4	DB9, female	Connection to serial async devices. Configurable to 300, 600, 1200, 2400, 4800, 9600, and 19.2, 28.8, 33.6, 38.4, 57.6, 115.2, 230.4 Kbps.
Power Connection	Terminal block	Non-polarized power input.
Facility Ground Point	Lug bolt	Facility ground connection point.
Console	DB9, female	Configured to operate at 38400 Baud, 8 bits, No parity, one stop bit and is configured as a DTE.
Alarm	DB9, female	Reserved for future use.



NOTE: All copper I/O connections must be made with shielded cables and connectors.

1.3.6 Indicators

The status indicators of the DX900 are described in [Table 1-6](#). There are two sets of LEDs so that you can conveniently monitor activity regardless of the orientation of the device. One set is on top to the DX900 (see [Figure 1-3](#)) and one set is on the front (see [Figure 1-1](#)).

Table 1-6. Indicators

LED Name	Condition	Indication
W1 (WAN DDS or T1/E1 Port)	Green	Indicates an active circuit.
	Off	Indicates circuit is down or not configured properly.
	Flashing	Data is passing through the port.

Table 1-6. Indicators

S1 – S4 (Serial Ports)	Green	Port is connected to an active serial device.
	Off	Port is down.
	Flashing	Data is passing through the port.
E1 – E4 (Ethernet Ports)	Green	Port is connected to an active Ethernet device.
	Off	Port is down.
	Flashing	Data is passing through the port.
Console	Green	Connected to an active local terminal.
	Off	Not connected.
	Flashing	Data is passing through the port.
Alarm	Off	No power is applied to unit.
	Red	Reset state: System is not loaded
	Orange	System is being booted.
	Green	Normal operation.

1.4 Pinouts

The following subsections describe the pinouts of the connectors used with the DX900.

1.4.1 RJ48

Table 1-7 defines the pinout of the RJ48 connector used on port W1 with the DDS or T1/E1 connection.

Table 1-7. RJ48 DDS or T1/E1 Pinout

Pin	Signal
1	Tx Data - Ring
2	Tx Data - Tip
3	not used
4	not used
5	not used
6	not used
7	Rx Data - Tip
8	Rx Data - Ring

Pin 1 . . . Pin 8

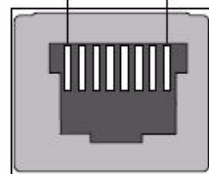

1.4.2 RJ45

Table 1-8 defines the pinout of the RJ45 connector used with the DX900. RJ45 connectors are used on ports E3 and E4 for 10/100 BaseT connections to copper Ethernet-capable devices.

Table 1-8. RJ45 Pinout

Pin	Signal
1	Tx +
2	Tx -
3	Rx +
4	not used
5	not used
6	Rx -
7	not used
8	not used

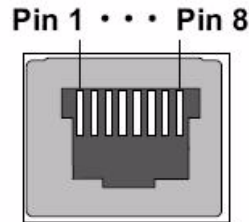

1.4.3 DB9 (Female) – RS232 Serial Ports and Console Port

Table 1-9 defines the pinout of the DB9 female connector for the console port and for serial ports S1 - S4 when they are configured for the RS232 interface. DB9 connectors are used on RS232 serial ports S1 - S4 and the console port, for asynchronous or bit-oriented connections.

Table 1-9. DB9 Pinout

Pin	Name	Dir.	Description
1	DCD	In	Data Carrier Detect from DCE.
2	RXD	In	Receive Data from DCE.
3	TXD	Out	Transmit Data to DCE.
4	DTR	Out	Data Terminal Ready to DCE.
5	GND	Pwr	Signal Ground.
6	DSR	In	Data Set Ready from DCE.
7	RTS	Out	Request To Send.
8	CTS	In	Clear To Send.
9	RI	In	Ring Indicator from DCE.

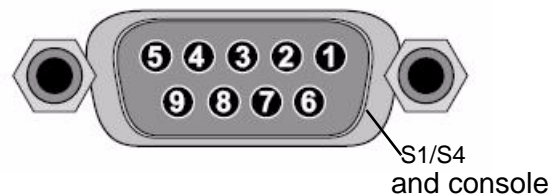

1.4.4 DB9 (Female) – Alarm Port

Table 1-10 defines the pinout of the DB9 female connector used with the alarm port on the DX900.

Table 1-10. DB9 Pinout

Pin	Signal
1	NO1 - normally opened 1
2	NC1 - normally closed 1
3	COM2 - common 2
4	Reserved for future use
5	GND - signal ground
6	COM1- common 1
7	NC2 - normally closed 2
8	NO2 - normally opened 2
9	Reserved for future use



1.4.5 DB9 (Female) – RS485 Serial Ports

Table 1-11 defines the pinout of the DB9 female connector used with serial ports on the DX900 when they are configured for the RS485 interface..

Table 1-11. DB9 RS485 Pinout

Pin	Signal	Direction
1	RX-	In
2	RX+	In
3	TX-	Out
4	TX+	Out
5	GND	Power
6	Not Used	
7	Not Used	
8	Not Used	
9	Not Used	



Chapter 2

Installation

This chapter provides specific procedures for installing the Magnum DX900, preparing for installation, and uninstalling the device.

2.1 Preparing for Installation

The DX900 is designed to be installed in standard 19" racks, on a DIN rail system, or on a panel.

2.1.1 Tools

Regardless of the mounting system you are using you will need the following tools:

- Two screw drivers – one phillips head and one slot.
- A torque wrench (rated for ten and 32 inch pounds, or 1.1 Nm and 3.6 Nm)
- A wrench to connect a ground wire from the device chassis to a ground

The instructions in this manual cover only the physical installation. System configuration is handled through a web-based interface and is described in the *Magnum Network Software – DX Administrator's Guide*.

2.1.2 Site Suitability

Be sure that your installation site meets the following criteria:

- Conforms with the temperature and humidity ranges detailed in [Table 1-2](#).
- Can meet the power requirements detailed in [Table 1-4](#).
- Will remain stable after the addition of the 5 lb. DX900.
- Permits at least two inches of space between the DX900 and any other heat-producing device.

2.1.3 Wiring and Grounding Guidelines

The DX900 requires several different types of connectors, cables, and wires. Requirements and recommendations are listed below:

- | | |
|-----------------------|--|
| Grounding | The primary ground stud located on the rear of the chassis must be used to connect to an approved ground with a wire meeting the following criteria: <ul style="list-style-type: none">• 14 AWG (minimum)• a maximum of five feet in length• terminated on the ground lug side with a #10 ring lug |
| Facility Power | The facility power cabling attached to the DX900 chassis must meet the following criteria: <ul style="list-style-type: none">• cabling constructed using 14 AWG stranded wire• cable firmly attached to the terminal holes of the non-polarized power unit, as illustrated in Figure 2-8.• cable routed and strain relieved to the chassis according to good wiring practices |
| Copper | Copper I/O cables and connectors must be shielded. |

2.1.4 External Connections

You can speed up the installation of the DX900 by having the following equipment and information on hand before beginning:

- A supply of cables and connectors of the required types.
- IP addresses for new devices and any existing devices you will be connecting to.
- Your notes on naming conventions and end point information.

2.2 Unpacking

Unpack and inspect the DX900.

The DX900 is shipped with the following items in the box:

- DX900 unit
- Appropriate mounting brackets (19' rail, **or** DIN rail, **or** panel), with screws
- Document CD-ROM
- Console Cable - DB9 terminations, 10' long
- Ethernet cable - RJ45 terminations, 10' long

Be sure that all the equipment you have ordered is included in the shipment.

Remove the unit from the styrofoam end caps and inspect the DX900 chassis for dents or other shipping related damage. Report any damage immediately to GarrettCom customer support and DO NOT INSTALL the unit.

2.3 Installation of the DX900 Unit

To install the DX900 you must first

- Mount it
- Make the ground and power connections.
- Connect the network cables

2.3.1 Mounting

Your DX900 shipment includes the mounting hardware you have ordered as appropriate to your site. This hardware is one of:

- A pair of 4.5" brackets for mounting in a 19" rail system
- A pair of 1.5" brackets for mounting on a panel.
- A DIN rail mounting bracket.

2.3.1.1 Mounting in a 19" Rail System

The brackets for mounting in a 19-inch rail system attach with two screws to the screw holes located toward the front of the DX900 (see [Figure 1-4](#)). You can adjust the depth of the device within the mounting system to four positions:

- By your selection of which pair of screw holes on the short side of the bracket (that is, the side that attaches to the DX900) to use.
- By setting the long side of the bracket (that is, the side that attaches to the rail system) toward the front of the DX900 or toward the rear.



Figure 2-1. 19" Rail Mounting brackets

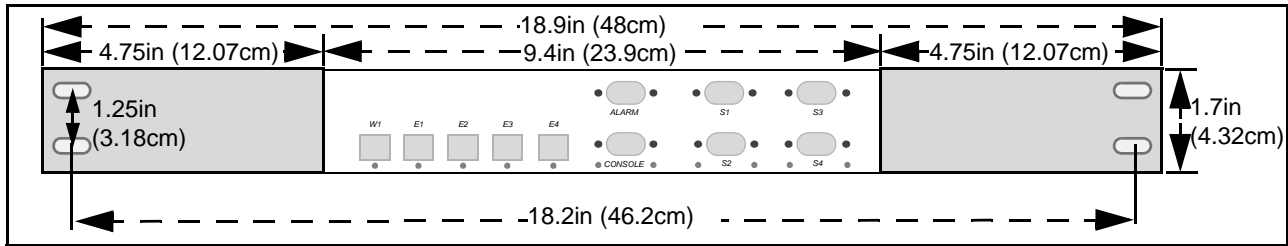

Figure 2-2. 19" Rail Mounting - Dimensional Drawing

2.3.1.2 Mounting on a Panel

Each bracket for mounting on a panel attaches with two screws to the screw holes located toward the rear of the DX900 (see [Figure 1-4](#)). You can adjust the distance of the DX900 from the panel to two positions by your selection of which pair of screw holes to use in attaching the bracket to the DX900.



Figure 2-3. Panel Mounting brackets

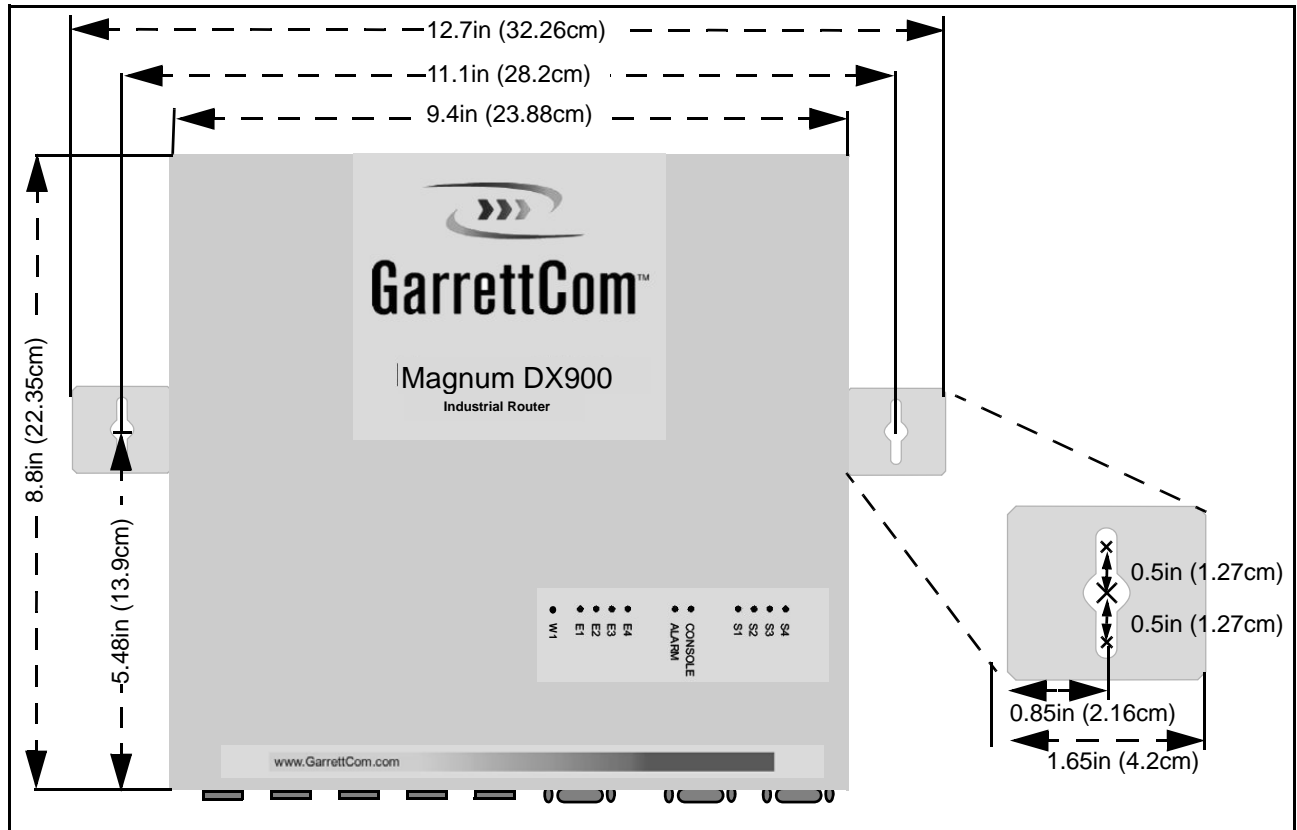

Figure 2-4. Panel Mounting - Dimensional Drawing

2.3.1.3 Mounting in a DIN Rail System

The DIN rail bracket rides on the bottom of the DX900 and is attached with four screws into the two pair of screw holes located toward the back of the DX900 (see [Figure 1-4](#)). The bracket attaches to the DIN rail by means of a pair of stationary prongs near the top of the bracket and a single spring-loaded prong (the release mechanism) toward the bottom of the bracket.

To fasten the DX900 into a DIN rail system begin by slipping the upper pair of prongs over the top of the rail. Then, while depressing the spring-loaded release mechanism (as illustrated in [Figure 2-5](#)), press the DX900 flush against the DIN rail and remove the screwdriver to allow the release mechanism to close. Check to make sure that the top and bottom prongs on the bracket are securely attached to the DIN rail.

When the DX900 is fastened into the DIN rail system it can be released by downward pressure on the release mechanism. The DIN rail bracket supplied with the DX900 is equipped with a metal “tail” that projects below the chassis of the mounted DX900. To unmount the DX900 insert the tip of a screwdriver into the slot at the bottom of this tail and pull up on the handle of the screwdriver to force the release mechanism down. Take care not to apply pressure to any I/O connector.

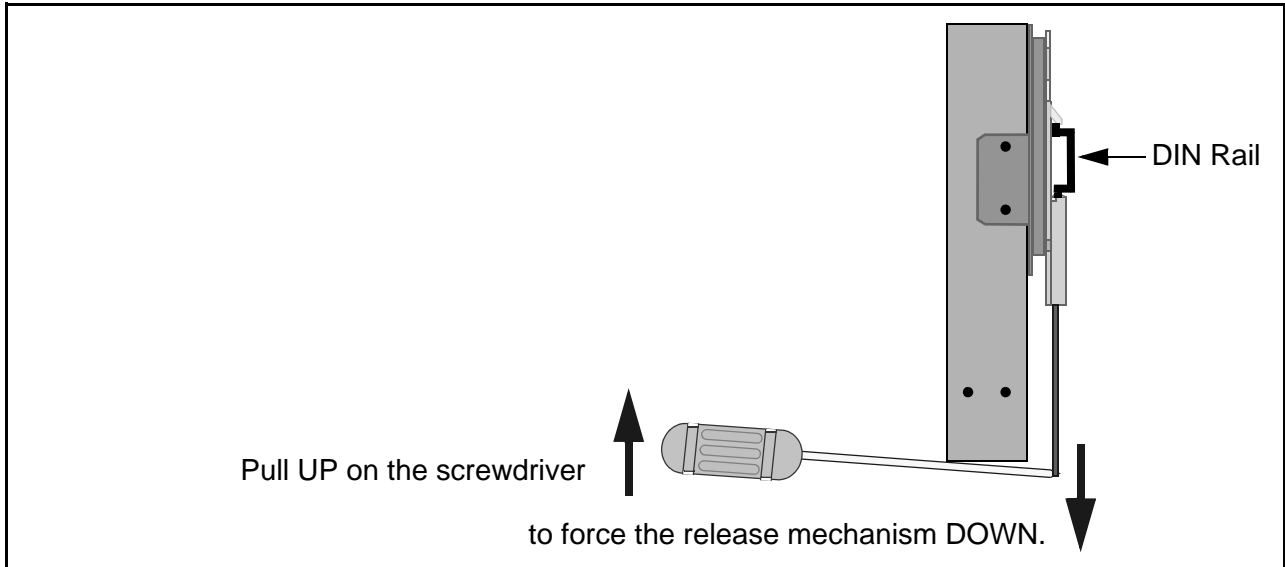

Figure 2-5. DX900 with DIN Rail bracket attached

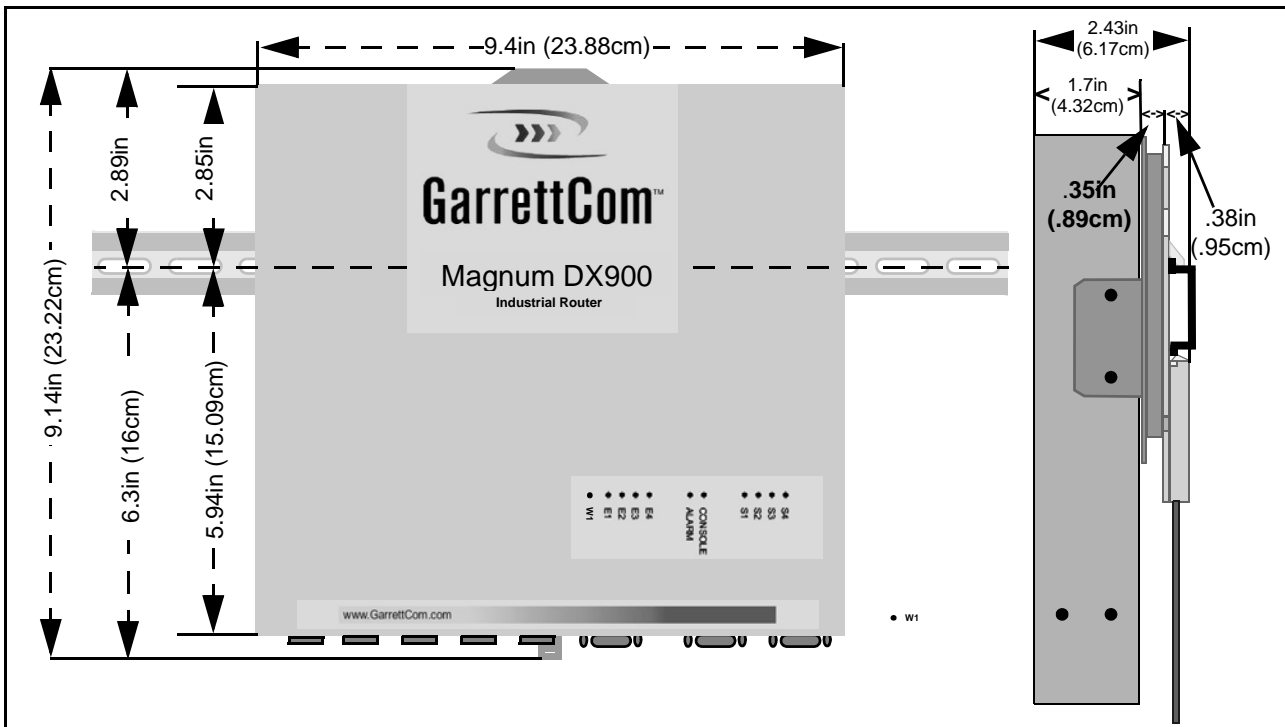

Figure 2-6. DIN Rail Mounting - Dimensional Drawing

2.3.2 Connecting Facility Power

The DX900 comes in either high or low voltage models. The unit does not have a power on/off switch and is active when the power is connected.



ELECTRICAL WARNING: Always ensure that the ground connection is made prior to connecting facility power to the DX900. The ground provides a protective circuit connection to ground in cases of transients and power surges. Connect the facility power to a DC or AC unit as described in the following sections.

2.3.2.1 Making the Ground and Power Connections

The DX900 provides a hardened DC or AC power supply for industrial applications and/or hostile environments. The ground lug and power supply connector are located on the rear of the unit as shown in [Figure 2-7](#).

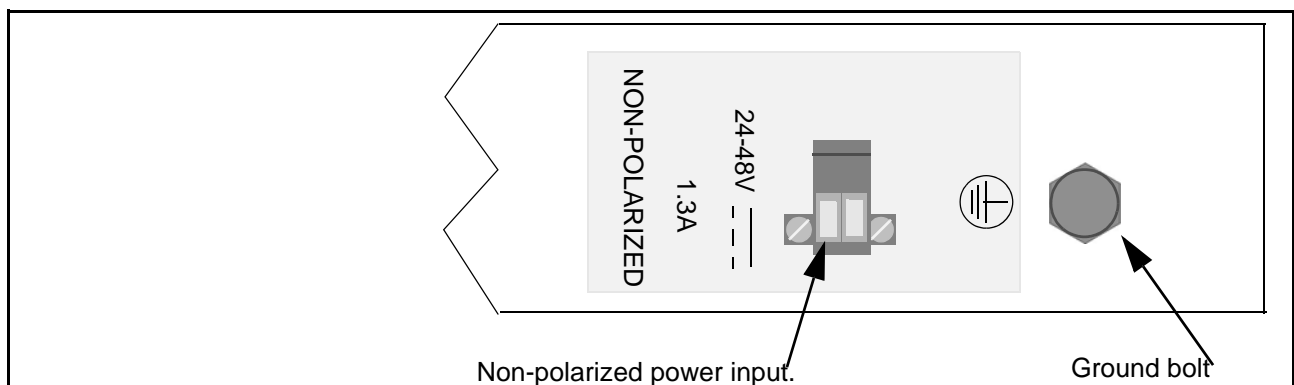

Figure 2-7. Ground and Power Connections



ELECTRICAL WARNING: Verify that a proper ground connection is made from the ground lug to facility ground prior to connecting power to the DX900. Failure to have a proper ground path could cause serious injury or death to personnel in cases of power surges.

Making the Ground Connection

The ground wire should be 14 AWG terminated with a #10 ring lug.

Make the facility ground connection as follows:

1. Loosen the ground bolt on the chassis, insert the #10 ring lug, and tighten the ground bolt.
2. Connect the other end of the ground wire to the facility ground.

Making the Power Connection

The power wires should be 14 AWG. Smaller wires may be used, down to 18 AWG, but verify that they meet your local electrical requirements.

Connect the power to the unit as follows.



ELECTRICAL WARNING: Ensure that power is disconnected from wiring prior to handling! Check the voltage rating next to the power connector - verify that it matches the power source.

1. Remove the plug portion of the power connector by loosening the two captive mounting screws.
2. Strip back 1/4" off the insulation of the wires that will connect the unit to the power source.
3. Loosen saddle screws and insert each conductor firmly into a terminal hole of the plug (**note: this connection is not polarity sensitive.**)
4. Visually inspect that no strands of wire are straying out of the hole, potentially shorting to ground or the other conductor. Tighten the saddle screws until the wires are secure.
5. Re-insert the plug into the power connector and secure the two captive mounting screws.

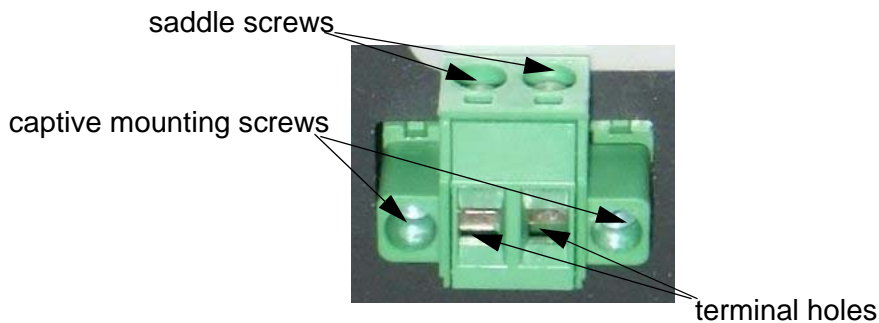

Figure 2-8. Non-Polarized Power Input

2.3.3 Connecting to the Console Port and the Alarm Port

2.3.3.1 Console Port

The Console Port enables configuration of the device and is connected by a serial cable to a PC. For hardware installation see [Section 2.3.4](#), below. For startup and configuration information see the the *Magnum Network Software – DX Administrator’s Guide*.

2.3.3.2 Alarm Port

The alarm port is not used in this version of the product. The LED associated with the Alarm port does report status information, as described in [Table 1-5](#). The port itself does not function. Do not connect anything to the Alarm port.

2.3.4 Connecting Network Cables

There are two types of connections that can be made to the DX900. They are serial and Ethernet copper. The following sections describe each type of connection separately.

2.3.4.1 Connecting Serial Cables

This procedure assumes that one end of the serial device cable is already attached to the end unit. Be aware of the serial port numbering scheme when installing the cables (see [Figure 1-1 on page 1](#)). The ports are configured in software later on and if a device is accidentally connected to the wrong port it will be difficult to detect.

Connect cables to the Serial ports as described below:

1. Align the DB9 connector with appropriate serial port and push gently until the connector is completely mated to the port.
2. Tighten the two extended capture screws hand tight.
3. Make sure that the connector is not supporting the whole weight of the cable. Providing strain relief on these cables will ensure a stable connection.
4. Return to step one above and connect the remainder of the serial cables.

2.3.4.2 Connecting Ethernet Copper Cables

The Ethernet ports are standard RJ45 ports. Connect the shielded Ethernet cables to the Ethernet ports as follows.(see [Figure 1-1 on page 1](#)).

1. Install the RJ45 connector into the port with the clip facing down.
2. Push the RJ45 connector into the slot until you hear a click.
3. Give the cable a gentle tug to ensure that the connector clip is firmly seated.
4. Verify that the connection has been made by checking the LED associated with this port on the top of the DX900 chassis. It should be illuminated. If the link LED is not illuminated verify that the equipment on the other end of the cable is powered up and properly connected.
5. Return to step one above and connect the remainder of the cables.

2.3.4.3 Connecting the WAN Cable

The single WAN connection on the DX900 can be a DDS or a T1/E1 port. An RJ48 is used for both the DDS and the T1/E1 ports. This is a modular connector that connects the DX900 to the external telecommunications network. The following procedure assumes that the line and telecom equipment are ready to accept data traffic from the DX900 and the interfacing cable is already attached to this gear.

Connect the RJ48-terminated cable to the WAN port as follows (see [Figure 1-1 on page 1](#)):

1. Install the RJ48 connector into the port with the clip facing down.
2. Push the RJ48 connector into the slot until you hear a click.

3. Give the cable a gentle tug to ensure that the connector clip is firmly seated.
4. Verify that the connection has been made by checking the LED associated with this port on the top of the DX900 chassis. It should be illuminated. If the link LED is not illuminated verify that the equipment on the other end of the cable is powered up and properly connected.

2.4 Maintenance

The DX900 is designed to be replaced as a unit. There are no servicing requirements and there are no user-repairable components in this device. Maintenance is limited to replacing the unit.

The following sections detail disconnecting all connections to the chassis, removing the chassis, cleaning optical devices and packing the DX900 for return to the manufacturer. If it is still possible to connect a terminal to the malfunctioning DX900 and retrieve any configuration data from the device, do so prior to removing power.

2.4.1 Removing the DX900

Removing the DX900 entails disconnecting the network cabling, disconnecting the power and ground lines, and removing the chassis from the rack or other installation location. The unit can then be packed for shipment to the manufacturer.

2.4.1.1 Disconnecting Network Cables

The sequence for removal of the serial and Ethernet cables is not important, but it is important to note that there are active devices connected to each end of the cable.

1. Remove all of the Async DB9 connectors from the serial ports by unscrewing the two captive screws on each cable and pulling the connector off the port. (Label the connector with the port number if the cable is to be reconnected at some later time.)
2. Remove the Ethernet RJ45 connectors from the Ethernet ports by pressing on the clip on the underside of the modular connector and pulling the connector straight out. (Label the connector with the port number if the cable is to be reconnected at some later time.) Repeat for the RJ48 WAN connector.

2.4.1.2 Disconnecting Power and Ground Lines



ELECTRICAL WARNING: Before disconnecting either AC or DC power connections at the DX900 ensure that the facility power has first been turned off. Failure to shut power off prior to removing the power connections could expose you to dangerous voltages causing injury or death.

Follow the procedure below to disconnect the power and ground lines.

1. Verify that power to the DX900 is turned off.
2. Use a screw driver to loosen the two screws that tighten the wire clamps in the non-polarized power connector. Remove the wires from the connector.



ELECTRICAL WARNING: If the wires are not to be used immediately properly insulate them to ensure that an accidental turning on of the power will not cause a short or electrical hazard.

3. Remove the ground wire from the chassis by loosening the Ground Lug.

2.4.1.3 Packing the DX900 for Shipment

If you have saved the shipping box that your DX900 was received in then add the end styrofoam pieces around the chassis and place the unit in the box. Please contact customer support to receive a valid RMA number so that this item is either repaired and returned or credited to your account. Products without a proper RMA number will not be accepted for repair by GarrettCom.

If you have not saved the original shipping container then place the unit in a box so that normal shipping activities will not cause any damage to the unit. GarrettCom has no responsibility for the product during return shipping. For more warranty information, see n [“Warranty” on page ii](#), and for details for the requirements for returning equipment, see [“Return Of Equipment” on page iii](#).

