



Industrial Fiber Optic Link/Repeaters*

Models 5845HRT and 5846HRT
Models 5845SHRT and 5846SHRT

User Manual

Document #3-44-0004-00
REV AD



25 Commerce Way North Andover, MA 01845
(978) 688-8807 • FAX (978) 688-8771
www.dymec.com

This page is left blank intentionally.

Warnings, Cautions, and Notes as Used in this Publication

WARNING

Warning notices are used in this publication to emphasize that hazardous voltages, currents, or other conditions that could cause personal injury exist in this equipment or may be associated with its use.

In situations where inattention could cause either injury or damage to equipment, a Warning notice is used.

CAUTION

Caution notices are used where equipment malfunction is possible if care is not taken.

NOTE

APPLICATION NOTE

Notes and Application Notes call attention to information that is especially significant to understanding and operating the equipment.

This document is based on information available at the time of its publication. While efforts have been made to be accurate, the information contained herein does not purport to cover all details or variations, nor to provide for every possible contingency in connection with installation, operation, or maintenance. DYMEC assumes no obligation of notice to holders of this document with respect to changes subsequently made.

DYMEC makes no representation or warranty, expressed, implied, or statutory with respect to, and assumes no responsibility for the accuracy, completeness, sufficiency, or usefulness of the information contained herein. No warranties of merchantability or fitness for purpose shall apply.

Permission is granted to make a reasonable number of copies of this document for the use within an organization that has purchased the equipment.

* Link/Repeater is used exclusively to describe DYMEC's unique family of Fiber Optic Data Links.

This page is left blank intentionally.

Table of Contents

	<u>Page</u>
1. Introduction	1-1
1.1 Definitions	1-1
1.2 Model 5845HRT and 5846HRT Link/Repeaters	1-5
1.2.1 9 Pin Data Port D-Connector	1-5
1.2.2 HD/FD Switch	1-6
1.2.3 Repeat Switch	1-6
1.2.4 Logic Inversion Switch	1-6
1.2.5 Input Bias Switch	1-6
1.2.6 Input Data Coupling Switch	1-7
1.2.7 Enable Holdover Switch	1-7
1.2.8 Test Mode Switch	1-8
1.2.9 Optical Ports	1-8
1.2.10 Diagnostic LEDs	1-9
1.2.11 Power Connections	1-10
1.2.12 Peripheral Equipment	1-11
2. Configurations, Operation, and Installation	2-1
2.1 Point-to-Point Configuration	2-1
2.2 Loop Operation - Master/Slave Configuration	2-7
2.3 Loop Operation - Peer-to-Peer Configuration	2-10
3. Applications	3-1
3.1 Data Rate	3-1
3.2 Optical Budget	3-1
3.2.1 Cable Attenuation Factors	3-1
3.2.2 Extending the Distance	3-2
3.3 Number of Repeats	3-3
3.3.1 Effects of Data Rate	3-3
3.3.2 Pulse Width Distortion	3-3
3.3.3 Temperature Effect	3-4
3.4 Powering the Link/Repeater	3-4
3.4.1 Model 5845HRT & 5845SHRT	3-4
3.4.2 Model 5846HRT & 5846SHRT	3-4
3.5 Input Bias Switch	3-5
3.5 Logic Inversion Switch	3-5
3.6 Echo Control for EIA 485 Master in Loop Configurations	3-6
3.7 Optional Station Power Voltages	3-6
3.8 Type of Communication	3-6
3.9 Selection of Fiber Optic Cable	3-6
4. Testing and Trouble Shooting	4-1
4.1 Testing	4-1
4.2 Trouble Shooting	4-2
5. Specifications	5-1
5.1 Electrical and Optical Specifications	5-1
5.2 Mechanical Dimensions of the 5845HRT & 5845SHRT	5-3
5.3 Mechanical Dimensions of the 5846HRT & 5846SHRT	5-4
6. Ordering Information	6-1

This page is left blank intentionally.

1. INTRODUCTION

DYMEC Models 5845HRT, 5845SHRT, 5846HRT and 5846SHRT are data communication Link/Repeaters which allow the replacement of copper wire with fiber optic cable. Link/Repeaters simply convert electrical signals to light for transmission, then, when received, convert the light signals to electrical. This is done in EIA 422 and EIA 485 formats.

Link/Repeaters are passive to software protocol. They are not addressable in communication protocols and do not provide any control logic capability to support communication protocols. Link/Repeaters are designed with several features that allow easy installation and flexibility in configuring for various communication systems.

Models 5845HRT and 5846HRT are similar except for the voltages by which they can be powered.

Models 5845SHRT and 5846SHRT have the same features and functionality described for the Models 5845HRT and 5846HRT respectively with the exception that they have single mode optics for use with single mode fiber cable.

NOTE

This manual makes reference to the Model 5845HRT and Model 5846HRT when describing features and functionality of the Link/Repeaters. These descriptions generally apply to the Model 5845SHRT and Model 5846SHRT as well. When different, a specific reference is made identifying the particular model(s) and their variation.

The User should read this entire manual to fully understand how to use the many features of the Link/Repeaters in an effective communication system.

1.1 DEFINITIONS

The following terms are used in this manual:

IED:

An IED is any intelligent electrical device capable of EIA 422 and/or EIA 485 data communications, such as; a computer, RTU, PLC, "smart" meter, relay, etc. The IED must have resident software or firmware that manages the data communication logic, including protocol (formatting and timing), addressing capability (if required), control logic software "handshaking", and scheduling.

Point-to-Point Configuration:

Two Link/Repeaters connected directly to each other.

Master/Slave Loop Configuration:

More than two Link/Repeaters connected together where the FOC connects the T optical port of one device to the R optical port of the next unit in the loop. One IED is designated as the Master and controls all the communication and the other IEDs act as Slaves and respond only when specifically polled by the Master.

Peer-to-Peer Loop Configuration:

More than two Link/Repeaters connected together where the FOC connects the T optical port of one device to the R optical port of the next unit in the loop. Each IED has the capability of becoming loop Master as allowed by the controlling software.

Echo:

The return of the Master's transmission back to the Master after traveling around the optical loop.

Optical Bus Configuration:

More than two Link/Repeaters connected together in a "linear" topology and there is no returning echo of a transmission.

Optical Star Configuration:

More than two Link/Repeaters connected together in a "Hub and Spoke" topology and there is no returning echo of a transmission.

Master:

The Master is the IED that controls the network in a Master/Slave configuration. This IED is responsible for the control of the network, the polling of the Slaves for information, and the prevention of data collisions. In a loop configuration, the Master's communication is echoed back to and stops at the Master. The Master's Repeat Switch is always in the "OFF" position.

Slave:

A Slave is an IED that is passive in a Master/Slave configuration. A Slave's communication is under the control of the Master, and only responds to specific poll requests from the Master.

Peer:

Peers are IEDs that have equal status and each may initiate a communication when allowed by the system software by a time slot, token, etc.

FOC:

Fiber Optic Cable.

Single-mode:

Single-mode fibers generally have diameters of 5µm to 13µm. Because of this small core, only one axial path for light propagation is available through the fiber. The optics required to drive single-mode fiber have to be highly focused so that minimum dispersion occurs. Though requiring more expensive optic emitters, the benefit is that longer transmission distances (<35 km) can be achieved.

Multi-mode:

Multi-mode fibers have core diameters of 50µm and larger. This larger core allows the light rays to be propagated along several different paths down the fiber. The different paths include an axial component as well as reflected components. Multi-mode units are economical and effective for transmission over distances up to 6 km.

Repeat Switch:

The Repeat Switch enables (REP) or disables (OFF) the repeater function of the Link/Repeater.

HD / FD Switch:

This switch adapts the Link/Repeater to accept independent transmit and receive channels (4 wire normally associated with EIA 422) or a shared transmit/receive channel (2 wire, generally EIA 485).

Data Coupling Switch:

This Switch adapt the Link/Repeater for either DC or AC electrical input data coupling. With AC data coupling, the minimum input data rate is 1600 baud. With DC data coupling there is no minimum input data rate, but a signal stuck high on the input will lock up a loop, bussed or star network.

Test Mode Switch:

Models 5845 and 5846 are provided with this switch to allow users who wish to test the fiber connections of the link with a built in diagnostic mode. This mode sends a 1KHz signal out the transmit port as well as looping back the copper port (pins 1 to 3 and 2 to 4) for diagnostic purposes. For the electrical connection this only works in Full Duplex Mode.

Enable Holdover Switch 0 and 1:

Models 5845 and 5846 provide two switch positions for the user to select one of four enable holdover times: 4uS (8 bit times at 2MBPS, the same as the previous generation 5845/46 links), 71uS (8 bit times at 112kBPS), 833uS (8 bit times at 9.6kBPS), and 8mS (8 bit times at 1kBPS) for the user. The factory default setting is 4uS.

Biasing Resistor Switch:

This switch allows the Link/Repeater to easily add or remove the device input bias resistors to reduce the loading on a copper bus network. The Bias resistors are 330 Ohms.

Simplex Communication:

Transmit only or receive only communications.

Half Duplex Communication:

Sequential transmit and receive communications.

Full Duplex Communication:

Simultaneous transmit and receive communications.

T:

Transmit optical port.

TE:

Diagnostic LED that illuminates when the Link/Repeater is receiving an electrical transmit from its IED.

TO:

Diagnostic LED that illuminates when the Link/Repeater is transmitting a signal optically.

R:

Receive optical port.

RE:

Diagnostic LED that illuminates when the Link/Repeater is delivering a received optical signal electrically to the IED.

RO:

Diagnostic LED that illuminates when the Link/Repeater is receiving a signal optically.

Optical Budget:

The optical budget is expressed in dB and is the amount of light loss tolerated for communication. The total distance between two devices that a signal can be transmitted is determined by subtracting all the losses of the optical circuit from the optical budget. Various factors in the optical circuit attenuate the light transmission and must be accounted for to assure a reliable optical circuit. Key factors include cable attenuation (expressed as dB per unit length), cable aging, and cable fittings (terminations, splices, splitters, etc.).

Non-Return to Zero (NRZ):

This type of encoding scheme does not require the voltage potential of each data bit to return to the zero potential. No clock or timing recovery is provided with this type of communication except in the start and stop bits usually found on each data word.

Return to Zero (RZ):

This type of encoding scheme requires the voltage potential of each data bit to return to the zero potential. This allows timing recovery with each bit instead of just the start and stop bits of the data word.

Number of Repeats:

The Number of Repeats is the number of Link/Repeaters that may be connected in a network when the Repeat function is required such as in loop configurations. The sum of Slaves in a Master/Slave loop is the number of repeats for that type of loop. The number of Peers minus one is the number of repeats in a Peer-to-Peer loop.

Asynchronous Communication:

This type of communication does not transmit a separate clock signal with the data signal. Link/Repeaters support asynchronous communication. A communication scheme where the clock needs to be transmitted (Synchronous Communication) is not supported unless the clock is embedded with the data.

1.2 MODEL 5845HRT AND MODEL 5846HRT LINK/REPEATERS

NOTE

Link/Repeaters contain no serviceable parts. Opening the unit will void the warranty.

Each Link/Repeater consists of the following elements shown in Figure 1.

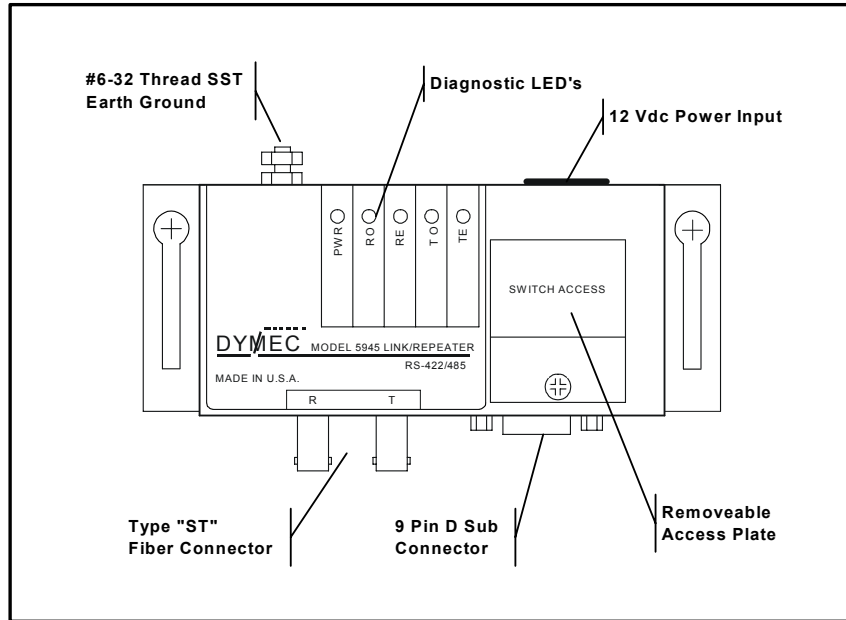

FIGURE 1. Elements of the Link/Repeater (5845HRT or 5845SHRT)

1.2.1 9 Pin Data Port D-connector

The Link/Repeater connects to an IED's EIA 422 or 485 communication port. The pin out configuration of the Link/Repeater is shown in Figure 2. If the IED's port is not a 9 Pin D-connector or if the IED's pin out configuration differs, an adapter is required.

HD Mode	FD Mode
<ul style="list-style-type: none"> • 1 Trans/Rec Data – [B/B'](I/O) • 2 Trans/Rec Data + [A/A'] (I/O) • 3 <i>No Connect</i> • 4 <i>No Connect</i> • 5 Signal Ground • 6 Earth Ground • 7 Repeat Enable/Disable • 8 Optical Enable/Disable • 9 +9-15 Vdc Power (Pin 5 GND) 	<ul style="list-style-type: none"> • 1 Transmitted Data – [B] (Link Input) • 2 Transmitted Data + [A] (Link Input) • 3 Received Data – [B'] (Link Output) • 4 Received Data + [A'] (Link Output) • 5 Signal Ground • 6 Earth Ground • 7 Repeat Enable/Disable • 8 Optical Enable/Disable • 9 +9-15 Vdc Power (Pin 5 GND)

FIGURE 2. Data Port Pin Assignments

1.2.2 HD/FD Switch

The HD/FD Switch adapts the Link/Repeater to accept independent transmit and receive channels or a single shared transmit/receive channel.

HD: In this position, the Link/Repeater accepts a shared transmit/receive communication channel such as normally associated with EIA 485 2 wire standards. When in the HD position, the Link/Repeater is "listening" for data signals both optically and electrically and automatically switches to the correct state. This position is normally used for EIA 485 2 wire connections and only half-duplex or simplex communication is available. Multi-drop networks may be either Peer-to- Peer or Master / Slave.

FD: When independent transmit and receive electrical channels are available, select the FD position. This will normally be used for EIA 422 or EIA 485 4 wire standards. The Link/Repeater can support full duplex, half duplex or simplex communication in this position. Multi-drop networks may only be Master / Slave.

1.2.3 Repeat Switch

The Repeat switch enables the repeater function in the "ON" position and disables it in the "OFF" position.

REP: The repeater function available in the Link/Repeater is enabled. This function converts the optical signal received on the R optical port to an electrical signal and delivers this signal to the appropriate pins of the 9 Pin connector, as well as, re-transmits the signal optically out the Link/Repeater's T optical port.

OFF: The repeater function available in the Link/Repeater is disabled. The Link/Repeater converts the optical signal received on the R optical port to an electrical signal and delivers this signal to the appropriate pin of the 9 Pin connector, and does not re-transmit the signal optically out the Link/Repeater's T optical port.

1.2.4 Logic Inversion Switch

Use of this feature is required when optically interconnecting IEDs using RS-232 to IEDs using EIA 422 or 485 or IEDs that have biasing that pulls the "A" (+) line high and the "B" (-) line low during the quiescent state. (Refer to Section 3.5)

1.2.5 Input Bias Switch

The Biasing resistor switch selects electrical input biasing. Biasing on RS422/485 inputs provides the ability for the inputs to a device (the Link/Repeater) to be in a known electrical state if the outputs that are connected to it go into a Tri-State (non driving) condition. Pins marked B or - are pulled to +5 volts and pins marked A or + are pulled to Signal Ground. The default for the biasing resistors is 330 Ohms, optionally no biasing can be selected.

Bias: 330 Ohm Biasing resistors. This is equivalent to 9 loads when configuring a bus network configuration.

Out: No biasing resistors. This is the equivalent to 1 load when configuring a bus network. This setting should be used on at least one Link/Repeater if there are 2 or more electrically connected IED's in a copper bus network segment.

1.2.6 Input Data Coupling Switch

The Data Coupling switch selects the electrical input conditioning, the AC position selects capacitively coupled, the DC position is directly coupled.

AC: AC coupling has a minimum incoming data requirement of 1600 baud due to the capacitive coupling. This option blocks DC electrical levels should the device connected fail and 'stick in a high level'. There is a 35 mS timeout for "stuck" output pins, after this time out the link returns to LED off state.

DC: DC coupling allows DC logic levels to be transmitted over the fiber network, care must be taken to guarantee that when any device stops transmitting packets that the input level returns to a state that allows the T receptacle (emitter) to turn off. If it does not and the LED is part of a loop, bussed or star network, the first device to transmit blocks all other devices on the network from transmitting. *Single-Mode units cannot be DC coupled.

1.2.8 Enable Holdover Switch

Since the 5845/46 Link/Repeaters are protocol and baud rate independent, we have no way of determining the end of a word or packet, and therefore, when to tri-state the EIA-422/485 driver. To overcome this obstacle, we drive '1' data bits for the full length of the bit and we drive '0' data bits for a pre-determined time. After that, the bias resistors hold the line in the '0' state. In most installations, the bias resistor circuit provides enough current for reliable communications, but in some cases (e.g. when our Link is electrically connected to many receivers) data errors can occur. We provide two dipswitch positions for the user to select one of four enable holdover times: 4uS (8 bit times at 2MBPS, the same as the previous generation 5845/46 links), 71uS (8 bit times at 112kBPS), 833uS (8 bit times at 9.6kBPS), and 8mS (8 bit times at 1kBPS) for the user to rectify this situation (See Figure 3). Extending the enable holdover time can improve the reliability of communications, but care must be taken to ensure that the enable holdover time does not exceed the minimum interpacket gap in that particular installation The factory default setting is 4uS.

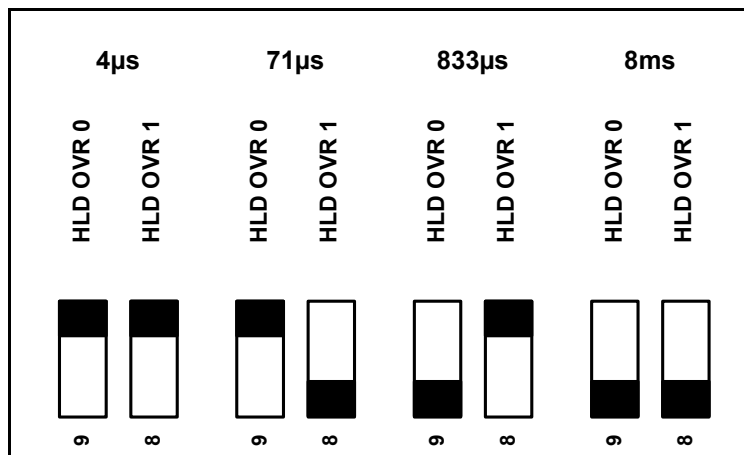

Figure 3 Enable Holdover Switch Settings

1.2.9 Test Mode Option Switch

Models 5845 and 5846 Links/Repeater are provided with this switch to allow users who wish to test the fiber connections of the link with a built in diagnostic mode. This mode sends a 1KHz signal out the transmit port as well as looping back the copper port (pins 2 to 4 and pins 1 to 3) for diagnostic purposes. The loop back option for the copper/electrical port of the Link/Repeater is only available for Full Duplex mode.

1.2.10 Optical Ports

There are two optical ports, T and R. The T optical port transmits data signals optically to the next Link/Repeater. The R port receives the optical data signal from another Link/Repeater's T optical port. Each port is fitted with an "ST" type receptacle for connecting the FOC. (See Figure 4).

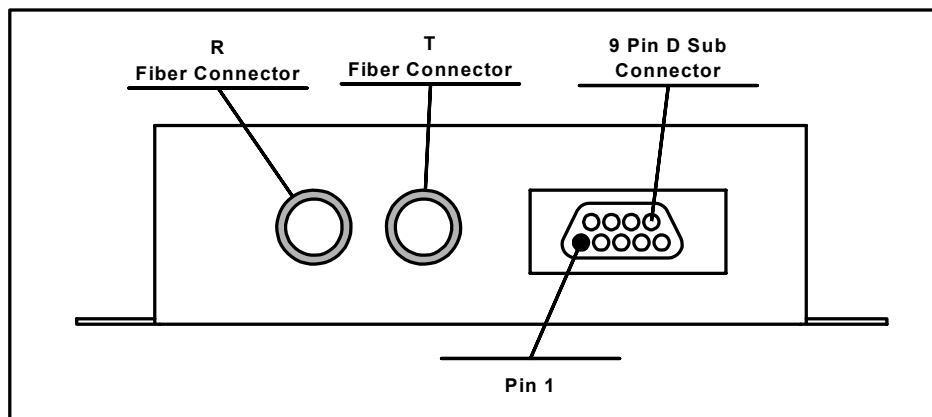

FIGURE 4. Optical Ports and 9 Pin Data Connection

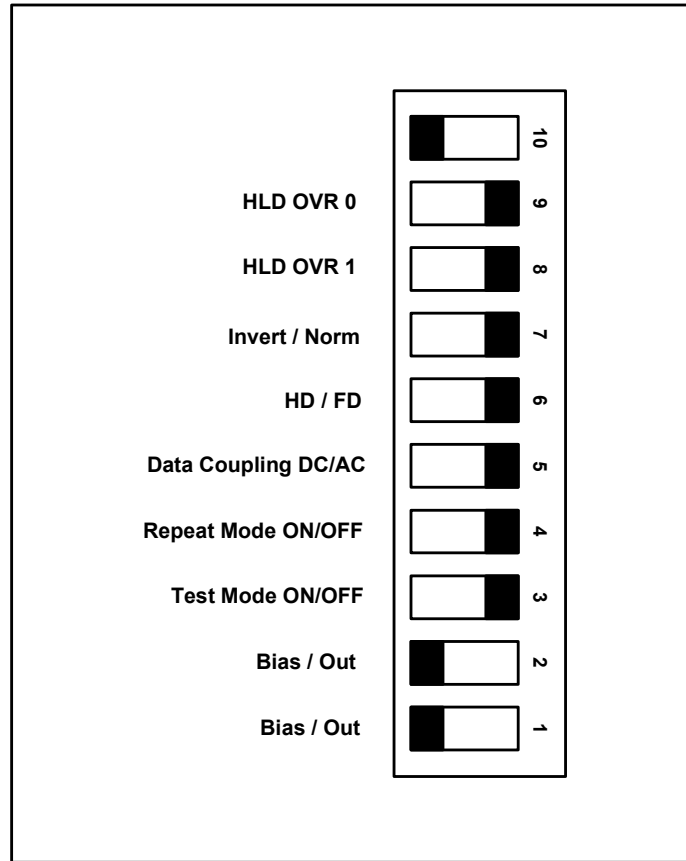

FIGURE 5. Switch Settings (Factory Defaults)

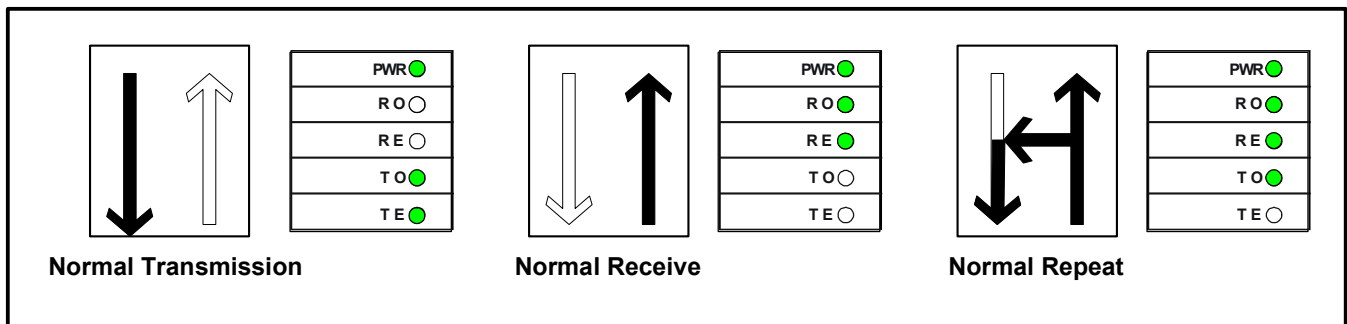

FIGURE 6. Diagnostic LED's and Data Signal Path

1.2.11 Diagnostic LEDs

Each Link/Repeater is equipped with four green diagnostic LEDs. They represent the electrical transmit (TE), optical transmit (TO), electrical delivery (RE), and optical receive (RO) paths. These LEDs, when illuminated, show that the appropriate path is active. When the Link/Repeater is transmitting, both TE and TO LEDs will illuminate to show the transmit path active. When the Link/Repeater is receiving light signals, both RO and RE LEDs will illuminate. If the unit is in the repeat mode and receiving light, the RO, RE and TO LEDs will illuminate because the signal is being re-transmitted out the optical port, as well as, being delivered to the D-connector. LEDs only

illuminate when the path is active; powering of the unit does not illuminate these LEDs unless their path is active. When data is present on the paths, the LEDs may "flicker"; this is normal. The diagnostic LEDs may be used for trouble shooting by observing that the illumination of the LEDs corresponds with activity in the unit. See Figure 6 for LED patterns and signal paths.

NOTE

The diagnostic LEDs only illuminate when there is signal traffic and are not illuminated during signal "quiet" times. If during quiet time, TE and TO are illuminated, it suggests either a polarity reversal (pins 1 & 2) or that the IED is biased pulling the "A" (+) line with respect to the "B" (-) line. After checking the polarity on the connections, refer to Section 3.5.

The diagnostic LEDs may "flicker" when data is passing. This is normal operation.

1.2.12 Power Connections

1.2.12.1 Powering Model 5845HRT and 5845SHRT

Model 5845HRT may be powered either through pin 9 of the 9 Pin D-connector or the power connector on the side of the unit:

- 1) When powering the 5845HRT via pin 9 (pin 9 + with pin 5 as GND) of its D-connector, the IED must supply at least 250 mA (340mA for the 5845SHRT). The voltage should be noise free and regulated within a range of 9 to 15 Vdc.
- 2) When powering the 5845HRT via its power connector the device requires regulated voltage within a range of 9 to 15 Vdc. DYMEC offers a 110 Vac to 12 Vdc adapter, Model 4310S (Model 4320S for 220 Vac 50 Hz) that is designed specifically for 5845HRT & 5845SHRT. Model 4310S assures reliable power over the temperature range of 0°C to + 70°C.

CAUTION

Regardless of the power connection used, Model 5845HRT requires 250 mA within a range of 9 to 15 VDC. The 5845SHRT requires 340 mA. An inadequate power supply not capable of supplying this current over the entire operating temperature range may cause the device to malfunction.

1.2.12.2 Powering the Model 5846HRT and 5846SHRT

Model 5846HRT and the 5846SHRT may be powered either through pin 9 of the 9 Pin D-connector or the power connector located on the side of the unit:

- 1) When powering Model 5846HRT via pin 9 (Pin 9 + with pin 5 as GND) of its D-connector, the IED must supply at least 250 mA (340mA for the 5846SHRT). The voltage should be regulated and within a range of 9 to 15 Vdc.
- 2) Model 5846HRT has an internal regulated switching power supply that may be connected directly to ac or dc station power. The station power may be 90 to 250 Vac, 50/60 Hz or 90 to 250 Vdc. The station voltage may be unregulated, but the circuit must be capable of providing a minimum of 45mA (60 mA for the Model 5846SHRT) continuously. Model 5846HRT has a ground stud (#6-32 bolt) and a power connector on the side of the case. If a Model 5846HRT is powered through

the power connector, then connect a suitable earth ground to the grounding stud on the side of the Link/Repeater. Loosen the captive screws and remove the power plug from the power connector of the Link/Repeater. Connect the power lines to the power plug being careful not to leave any wire strands exposed.

NOTE

Model 5846HRT can be ordered to accommodate 24 - 48 Vdc (requires 250 mA)

This power input to the Model 5846HRT-L is Surge Withstand Protected to IEEE 1613 for all input voltages.

WARNING

When installing a Model 5846HRT or 5846SHRT Link/Repeater, an earth Ground must be attached to the Ground Stud on the side of the case before connecting to power. Failure to follow this procedure may result in electrical shock to personnel.

1.2.13 Peripheral Equipment

1.2.13.1 IED

An IED is any intelligent electrical device such as; a computer, RTU, PLC, "smart" meter, relay, etc., that has the ability to communicate data via EIA 422 or EIA 485 format. The IED should have a communication port for the connection of the Link/Repeater. If the IED's communication port connector does not accept the Link/Repeater to be plugged in directly, an adapter must be made to accommodate the connection. Care should be taken to assure that the correct signals are connected to each other. See Figure 2 for the Link/Repeater's pin signal assignments. Check your IED's equipment manual for its signal assignments.

The IED must also have intelligent software to execute the data communication. This intelligence needs to logically manage the data and signal traffic, including any addressing, token passing, "handshaking", data formatting and scheduling.

1.2.13.2 Fiber Optic Cable (FOC)

The selection of the fiber optic cable is important. High quality cable can assure the maximum performance of your Link/Repeater. Important factors to consider are the manufacturer's specification on attenuation per unit length, attenuation due to aging, diameter, and tensile strength. Choosing the best quality FOC for your installation is important.

NOTE

DYMEC can supply multi-mode glass FOC in Simplex, Duplex, or Breakout construction, cut to length, terminated, polished and tested. The specifications for all DYMEC supplied cables are as follows:

Fiber Diameter:	62.5/125µm
Tensile Strength:	100 kpsi
Loss:	3 dB per kilometer
Aging Loss:	less than 3 dB

Models 5845HRT and 5846HRT
Models 5845SHRT and 5846SHRT
EIA 422 or 485

Model 5845HRT and Model 5846HRT Link/Repeater optical ports are designed for ST type terminations and are compatible with multi-mode FOC ranging from 50 μm to 200 μm .

Model 5845SHRT and Model 5846SHRT Link/Repeater optical ports are designed for ST type terminations and are compatible with single-mode FOC ranging from 5 μm to 13 μm .

2. CONFIGURATIONS, OPERATION, AND INSTALLATION

Model 5845HRT and Model 5846HRT Link/Repeaters can be connected in; a Point-to-Point configuration, an Optical Bus network, an Optical Star network, a Master/Slave Loop, or a Peer-to-Peer Loop configuration depending on the needs of the overall communication system.

Model 5845HRT and Model 5846HRT are designed to accept differential electrical inputs per EIA 422 and EIA 485 standards. Various implementations of these electrical standards can result in different types of electrical circuits. The EIA 422 standard and the EIA 485 4 wire standard are normally associated with independent and separate transmit and receive channels. In Multi-drop networks, these standards allow Master / Slave operation only.

The EIA 485 2 wire standard generally uses a bi-directional, shared transmit/receive channel. In multi-drop networks, either Peer-to-Peer or Master / Slave operation is possible. The HD/FD switch on each Model 5845HRT and Model 5846HRT configures the Link/Repeater to accept either condition.

When the HD/FD switch is in the HD position, the Link/Repeater operates in half duplex mode only and both transmit and receive signals share pins 2 (A) and 1 (B).

In the FD position, Link/Repeater pins 2 (A) and 1 (B) connect to the IED's transmit channel. Link/Repeater pins 4 (A') and 3 (B') connect to the IED's receive channel.

NOTE

Some IEDs use "+" and "-" labels for their signals. A and A' are "+" and B and B' are "-".

It is possible to optically connect Link/Repeaters together which are connected to IEDs with different electrical formats, i.e. EIA 422, EIA 485 4 wire and EIA 485 2 wire. It is also possible to optically interconnect Models 5845HRT and 5846HRT to DYMEC Models 5843HRT and 5844HRT which are connected to IEDs operating RS 232 or TTL formats. See section 3.5.

APPLICATION NOTE

DYMEC Models 5843HRT, 5844HRT, 5845HRT and 5846HRT can optically communicate to each other, eliminating the need for format translation interfaces, provided all connected devices are operating at the same data rate and using the same protocol. (Refer to Section 3.5).

2.1 POINT-TO-POINT CONFIGURATION

For Point-to-Point operation, two Link/Repeaters are optically connected to each other. The HD/FD switch is set to the position that satisfies the IED that is connected to the Link/Repeater.

This configuration permits half duplex communication (sequential transmitting and receiving) and simplex (transmitting or receiving only) when the HD/FD switch is in either position. Full duplex is only available for circuits with independent transmit and receive channels where the HD/FD switch is placed in the FD position.

APPLICATION NOTE

In Point-to-Point operation, the communication logic (control software) of the IEDs must manage:

- 1) **The transmission of data signals.**
- 2) **The receipt of data signals.**
- 3) **Any "handshaking" required must be accomplished through software.**

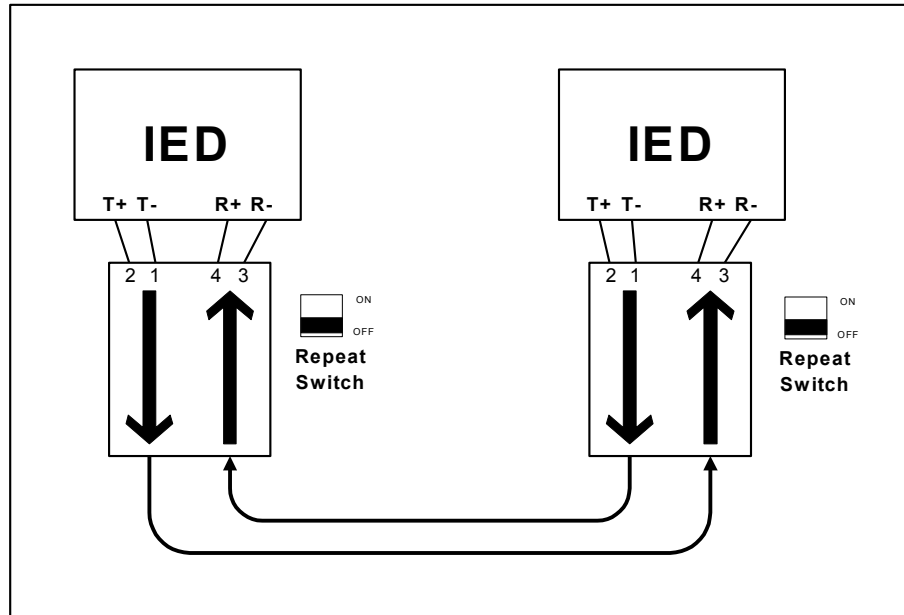

FIGURE 7. Point-to-Point Configuration

2.1.1 Installation

1. Set the HD/FD Switch to the appropriate position for each Link/Repeater and its respective IED.
2. Set the Repeat Switch on all of the units to the "OFF" position.
3. Connect the Link/Repeater to the IED's EIA 422 or 485 communication port (including any adapter that may be needed).
4. Connect the Fiber Optic Cables (T of one device to R of the second device).
5. Connect power to the Link/Repeater as follows:
 - A) If the unit is to be powered through the D-connector (+ 9 to + 15 VDC on pin 9 with pin 5 used as GND), then the unit is energized when it is connected to the D-connector and the green "POWER" LED illuminates.
 - B) If the unit is to be powered through power connector, connect the appropriate power source and energize the power source. The unit is now powered and the green "POWER" LED illuminates.

WARNING

When installing a Model 5846HRT or 5846SHRT Link/Repeater, an earth Ground must be attached to the Ground Stud on the side of the case before connecting to power. Failure to follow this procedure may result in electrical shock to personnel.

6. The units are now installed and operating.
7. Verify operation using the diagnostic LEDs. (See Figure 5).

NOTE

The diagnostic LEDs only illuminates when there is signal traffic and are not illuminated during signal "quiet" times. If during quiet time, TE and TO are illuminated, it suggests either a polarity reversal (pins 1 & 2) or that the IED is biased pulling the "A" (+) line with respect to the "B" (-) line. After checking the polarity on the connections, refer to Section 3.5.

The diagnostic LEDs may "flicker" when data is passing. This is normal operation.

APPLICATION NOTE

The Point-to-Point concept can be used to create an "optical bus" network. This can be useful for those situations where the software in the Master has not been written in such a way that it can handle the return of the transmitted echo that occurs in loop networks.

Figure 8 shows the connections for a Master/Slave EIA 422 "optical bus". Note that EIA 422 Standards do not permit multiple transmitters to be connected together as they are not tri-stated. In this configuration, all Slaves hear the Master's transmission, but only the Master hears the response from the addressed slave. The Master must always be the first IED in the network.

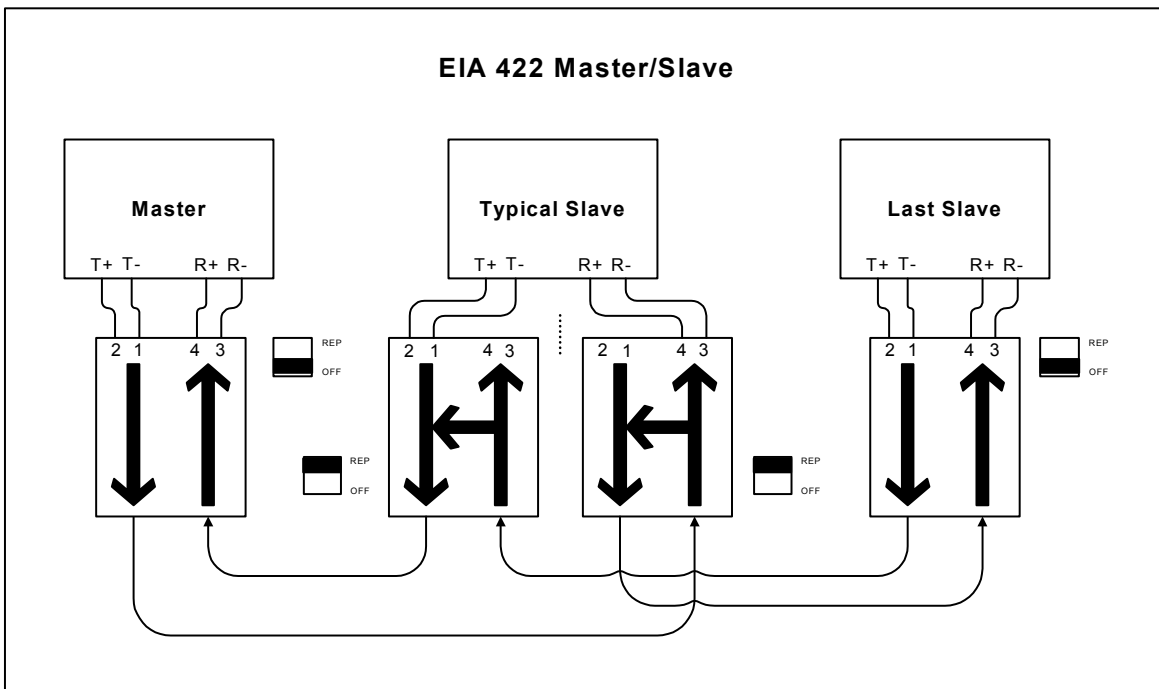

FD is selected on all Link/Repeaters
 All Slaves hear the Master's Poll, only the Master hears the response

FIGURE 8. EIA 422 Bus Configuration

Figure 9 depicts an EIA 485 multiple drop "optical bus" for both 4 wire and 2 wire systems. The 4-wire system is a Master/ Slave configuration. All the Slaves hear the Master's poll, but only the Master can hear the addressed Slave's response and the Master must be the first IED in the network. However, in the 2-wire configuration, the system is capable of operating as Peer to Peer or Master/Slave. All IEDs hear all communications and the Master may be located at any point in the network.

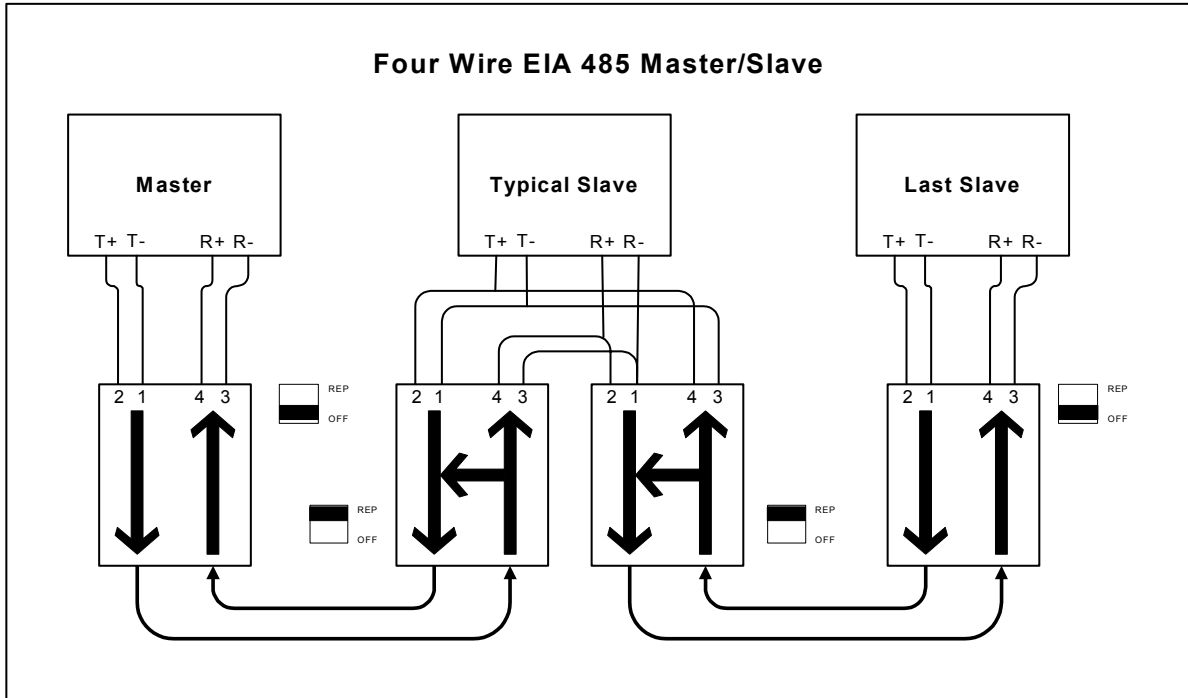

All Slaves hear the Master's Poll, only the Master hears the response
 FD is selected on all Link/Repeaters

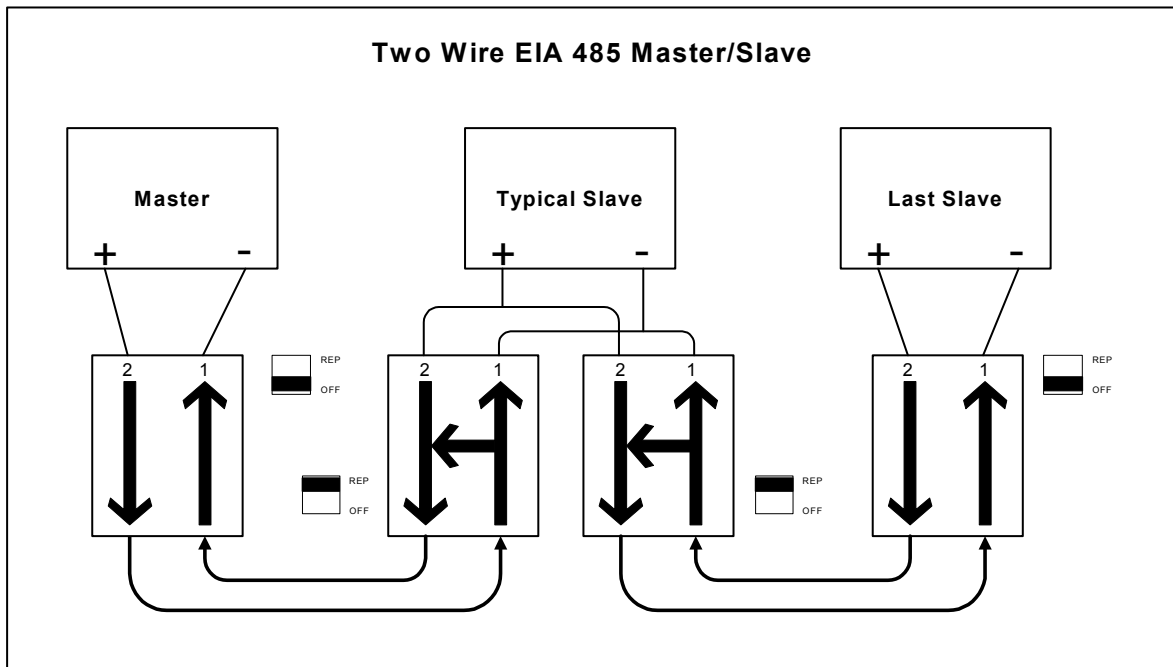

All IEDs have the ability to hear and to respond to each other
 HD is selected on all Link/Repeaters

Figure 9. EIA 485 Bus Configurations

APPLICATION NOTE

Another variation of the point-to-point concept is the Optical Star network. This topology may be created using the Dymec Optical Star OS5M or OS9M. This topology creates a “Hub and Spoke” configuration that can be useful in solving a network configuration based upon the physical positioning of the nodes.

The Dymec Optical Stars can also be used to create a multi-drop Master / Slave Optical Star network. The Model 5845HRT and 5846HRT are optically compatible with the OS5M and OS9M Master and Slave ports. Figure 10 shows a typical connection of an Optical Star network.

The master IED must always be connected to the Master port of the Optical Star. The slave IED's must always be connected to the Slave ports of the Optical Star.

Variations of this configuration are as follows:

- The optical star may be the last node of an optical bus configuration. One may create an Optical Bus configuration starting with the Master IED to a series of Slave IEDs and then connect the fiber network to the Master port of the OS4M or OS8M to continue the network in a “Hub and Spoke” topology.
- A Master IED may be connected to the master port of an OS5M or OS9M and then an Optical Bus network may be created from any Slave Port of the Optical Star.
- The Optical Stars maybe “cascaded”. Cascading means optically connecting a Slave Port of one Optical Star to the Master Port of the next Optical Star.
- IEDs of different electrical formats (i.e., RS-232, EIA 422, EIA 485 2-wire or EIA 485 4-wire) may also be interconnected optically in the Star Configuration. Refer to section 3.5.

NOTE

It is not recommended that a “loop network” be connected to an Optical Stars Slave Port

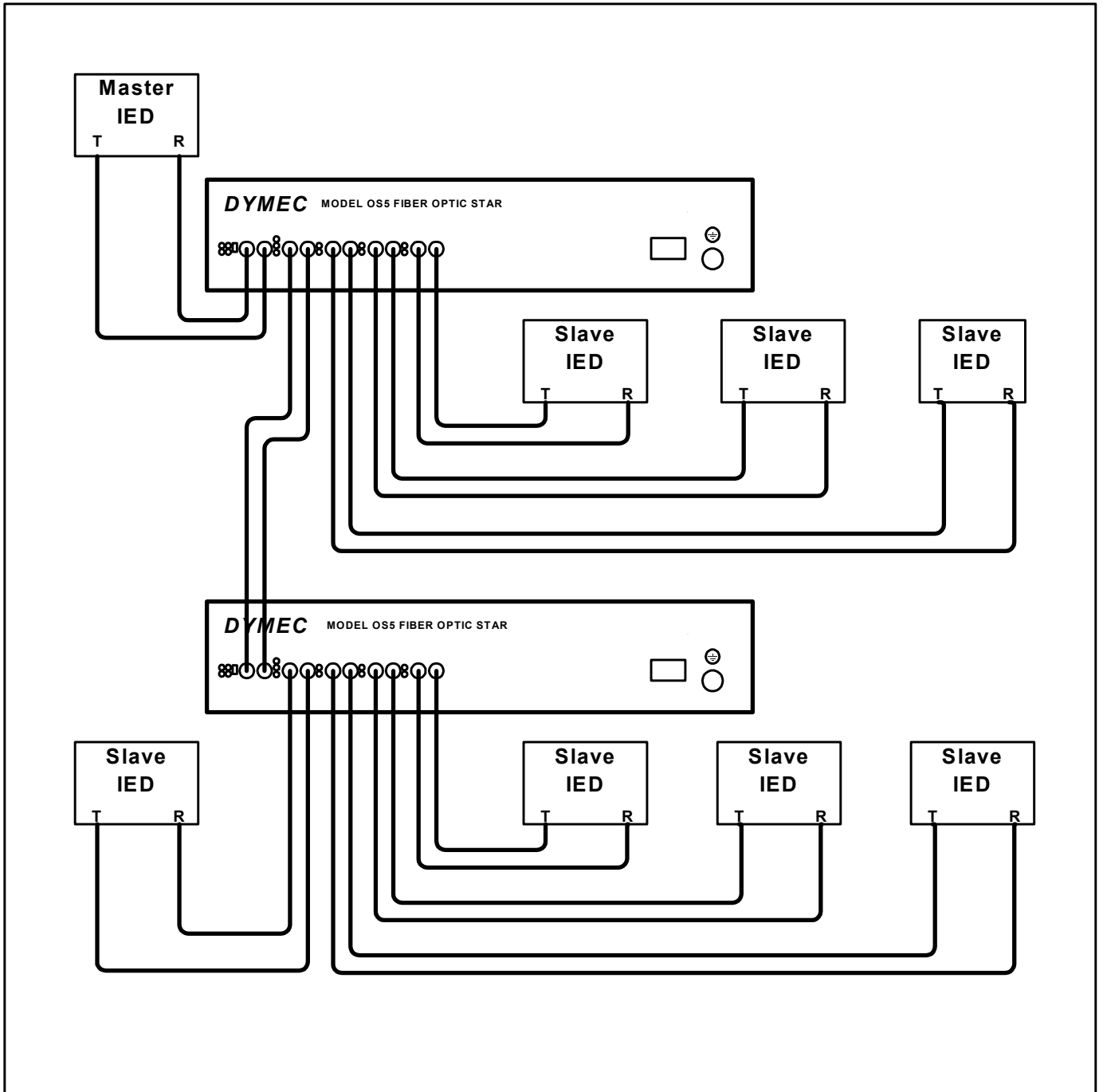

**FIGURE 10. Optical Star Configuration
(OS5M cascaded to an OS5M)**

2.2 LOOP OPERATION - MASTER/SLAVE CONFIGURATION

NOTE

Before constructing a loop network, be sure that the software protocol of the Master is capable of managing the receipt of its own echoed transmission. If it cannot, then use either an Optical Bus or Optical Star configuration.

This configuration supports a system that requires more than two IEDs to be communicating. In a Master/Slave loop system, one IED acts as a Master at all times and addresses or "polls" each of the other connected IEDs individually. Each Slave receives the same transmission from the Master IED but only responds when it recognizes its address in the polling message.

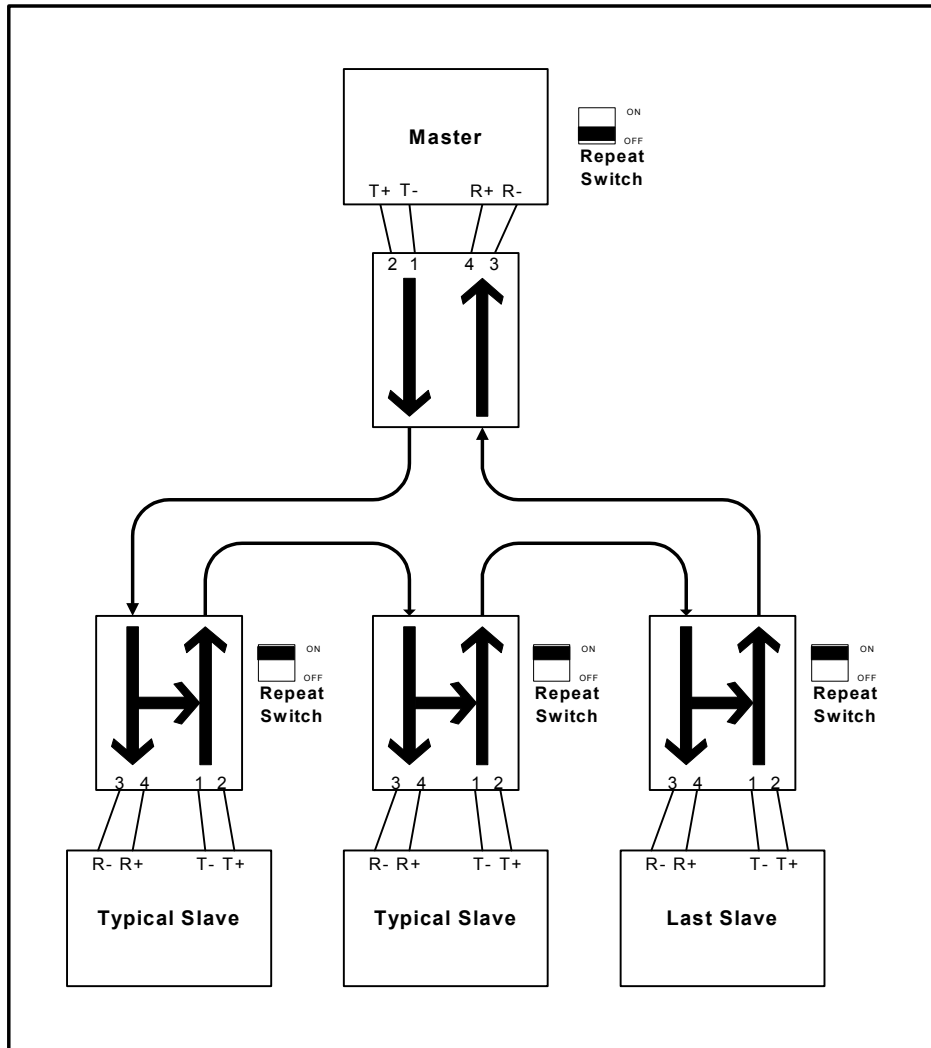

FIGURE 11. Master/Slave Loop Configuration

The Master must have its Repeat Switch in the "OFF" position. When it transmits a request out its T optical port, it will receive the echo of its request at its R optical port. This request has gone around the loop, and has been repeated by each Slave in the loop. However, the Master does not repeat (re-transmit) any of these received signals optically back around the loop, because its Repeat Switch is in the "OFF" position.

NOTE

The communication logic and control software of the Master IED must be able to manage the receipt of its echoed request. In the FD Mode, the receipt of the echo can be used in conjunction with a watchdog timer to continuously verify loop integrity.

When addressed, the Slave will transmit the appropriate response. Each Link/Repeater connected to a Slave IED must have its Repeat Switch set in the "ON" position. In this mode, all signals received on a Slave's R optical port are delivered to the IEDs communication port and at the same time repeated out the T optical port to the next device in the loop. If an IED determines that this request requires a response, then the Link/Repeater transmits the IEDs response out the T optical port. The response is repeated at each Slave device, until it arrives at the Master.

When an IED is a Slave, it should not attempt to initiate a transmission while it is receiving a signal. Since signals being received are also being repeated at the same time, any attempts to transmit its response while still receiving can corrupt both transmissions due to a data collision.

CAUTION

If a Slave IED attempts to transmit while receiving a message, a data collision will occur.

In Master/Slave Loop Operation, half duplex communication (sequential transmit and receive functions) is available. Only the Master can communicate full duplex (simultaneous transmit and receive) in a Master/Slave loop, provided its IED has independent Transmit and Receive channels, and the Link/Repeater HD/FD Switch is placed in the FD position.

CAUTION

If the Master IED operates in half duplex mode, special steps must be taken to control the echo. (Refer to Section 3.6.)

APPLICATION NOTE

In a Master/Slave Loop Operation, the communication logic (control software) and the Master IED must manage:

- 1) The transmission to Slaves (including addressing).**
- 2) The receipt of the echo of its transmissions.**
- 3) The receipt of the Slave's response to its transmission.**
- 4) The control of the Slaves to prevent the initiation of a transmission while receiving a signal.**

2.2.1 Installation

1. Set the HD/FD Switch to the appropriate position for each Link/Repeater and its respective IED.
2. Set the Repeat Switch to the "OFF" position on the Master. Set the Repeat Switch to the "ON" position on each Slave.
3. Connect the Link/Repeater to the IED's EIA 422 or 485 communication port (Including any adapter that may be needed).
4. Connect the Fiber Optic Cables (T of one device to R of the next device in the loop). Continue around the loop back to the Master to close the loop.
5. Connect power to the Link/Repeater as follows:
 - A) If the unit is to be powered through the D-connector (9 to 15 VDC on pin 9 with pin 5 used as GND), then the unit is energized when it is connected to the D-connector of the IED and the green "POWER" led illuminates.
 - B) If the unit is to be powered through the power connector, connect the appropriate power source and energize the power source. The unit is now powered and the green "POWER" LED will illuminate.

WARNING

When installing a Model 5846HRT or 5846SHRT Link/Repeater, an earth Ground must be attached to the Ground Stud on the side of the case before connecting to power. Failure to follow this procedure may result in electrical shock to personnel.

6. The units are now installed and operating.
7. Verify operation using the diagnostic LEDs. (See Figure 5)

NOTE

The diagnostic LEDs only illuminate when there is signal traffic and are not illuminated during signal "quiet" times. If during quiet time, TE and TO are illuminated, it suggests either a polarity reversal (pins 1 & 2) or that the IED is biased pulling the "A" (+) line with respect to the "B" (-) line. After checking the polarity on the connections, refer to Section 3.5.

The diagnostic LEDs may "flicker" when data is passing. This is normal operation.

2.3 LOOP OPERATION - PEER-TO-PEER CONFIGURATION

NOTE

Before constructing a loop network, be sure that the software protocol is capable of managing the receipt of the echo of its own transmission. If it cannot, then use either an Optical Bus or Optical Star configuration.

A Peer-to-Peer loop configuration is similar to the Master/Slave loop configuration except that each IED in the loop is capable of Mastering the loop in a pseudo-Master/Slave loop. To achieve this, Models 5845HRT and 5846HRT provide an electrical means of controlling the "OFF/REP" function.

In this system, all Link/Repeaters are connected in a loop with their Repeat Switch in the "OFF" position. Each IED must be able to control pin 7 of the D-connector to enable and disable the "REP" function. When an IED applies a high potential (greater than 2.4 Vdc – but less than 30V) it enables the repeat function of the Link/Repeaters. This is equivalent to the Repeat Switch being in the "REP" position. When an IED wishes to become the loop Master, it lowers the potential on pin 7 to a voltage less than 0.8 Vdc. This disables the Link/Repeaters' repeat function as if the Repeat Switch were in the "OFF" position.

NOTE

The communication logic and control software of the Master IED must be able to manage the receipt of its echoed request. In the FD Mode, the receipt of the echo can be used in conjunction with a watchdog timer to continuously verify loop integrity.

The voltage levels to enable and disable the repeat functions is opposite the levels used in the previous generation of Dymec Link/Repeaters.

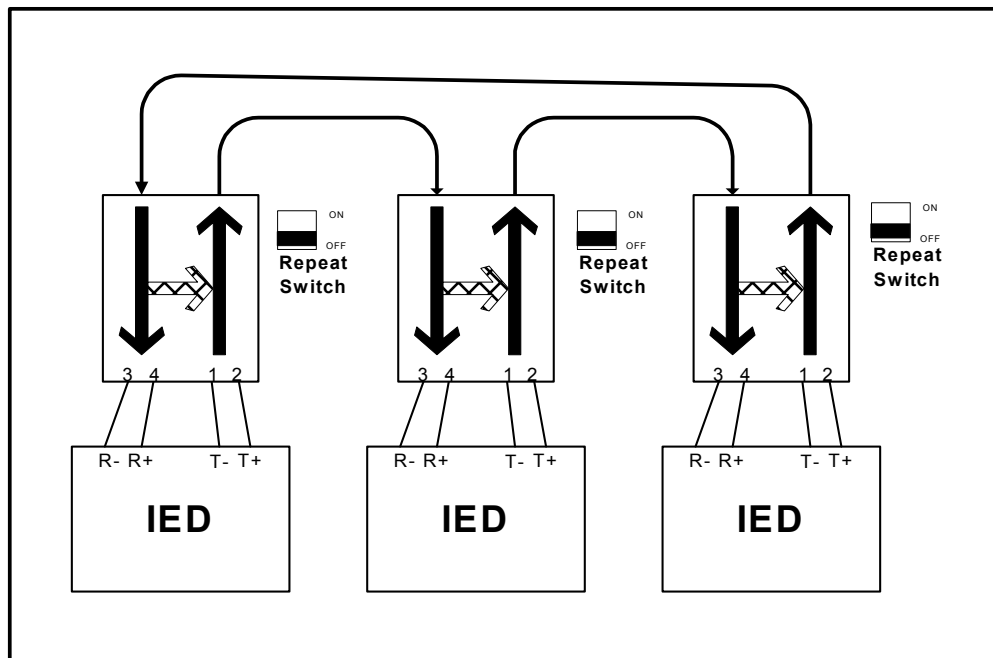

FIGURE 12. Peer-to-Peer Loop Configuration

When the potential on pin 7 is high, signals received on the R optical port are delivered to the IED and are repeated out the T optical port to the next device in the loop. A low potential on pin 7 causes signals received on the R optical

port to be delivered to the IED only and are not repeated out the T port. It is not necessary for a Slave to lower the potential of its pin 7 to transmit.

After an IED has completed its tasks mastering the loop, it must return its pin 7 to a high potential enabling its repeater function to establish loop continuity for the next IED that becomes loop Master.

NOTE

Powering and Controlling pin 7 can be ignored in all configurations except Peer-to-Peer loop operation.

Only half duplex communication is available with this configuration.

When an IED is in the Slave state, it should not attempt to initiate a transmission while it is receiving a signal. Since signals being received are also being repeated at the same time, any attempt to transmit its response while still receiving, can corrupt both transmissions due to a data collision.

NOTE

Any Link/Repeater that has its Repeat Switch in the "OFF" position and has a low potential on pin 7 will not repeat signals received on its R optical port out of its T port. Only transmissions initiated by its IED are transmitted out its T optical port.

CAUTION

If any IED operates as a Master and is 2 wire EIA 485 (half duplex), special steps must be taken to control the echo. (Refer to Section 3.6)

APPLICATION NOTE

In Peer-to-Peer loop operation, the communication logic (control software) and the Master IED must manage:

- 1) **The transmission to Slaves.**
- 2) **The receipt of the echo of its transmissions.**
- 3) **The receipt of the Slave's response to its transmission.**
- 4) **The control of pin 8 of D-connector.**
- 5) **The control of the Slaves to prevent the initiation of a transmission while receiving a signal.**

2.3.1 Installation

1. Set the HD/FD Switch to the appropriate position for each Link/Repeater and its respective IED.
2. Set the Repeat Switch on all the units to the "OFF" position.
3. Connect the Link/Repeater to the IED's EIA 422 or 485 communication port (Including any adapter that may be needed).
4. Connect the Fiber Optic Cables (T of one device to R of the second device). Continue around the loop to complete the loop.

5. Connect power to the Link/Repeater as follows:
 - A) If the unit is to be powered through the D-connector (9 to 15 VDC on pin 9 with pin 5 used as GND), then the unit is energized when it is connected to the D-connector of the IED and the green "POWER" LED will illuminate.
 - B) If the unit is to be powered through the power connector, connect the appropriate power source and energize the power source. The unit is now powered and the green "POWER" LED will illuminate.

WARNING

When installing a Model 5846HRT or 5846SHRT Link/Repeater, an earth Ground must be attached to the Ground Stud on the side of the case before connecting to power. Failure to follow this procedure may result in electrical shock to personnel.

6. The units are now installed and operating.
7. Verify operation using the diagnostic LEDs. (See Figure 5)

NOTE

The diagnostic LEDs only illuminates when there is signal traffic and are not illuminated during signal "quiet" times. If during quiet time, TE and TO are illuminated, it suggests either a polarity reversal (pins 1 & 2) or that the IED is biased pulling the "A" (+) line with respect to the "B" (-) line. After checking the polarity on the connections, refer to Section 3.5.

The diagnostic LEDs may "flicker" when data is passing. This is normal operation.

3. APPLICATIONS

When planning a system using Model 5845HRT and Model 5846HRT Link/Repeaters, the following considerations should be reviewed:

- Data Rate
- Optical Budget and the distance between connected units
- Number of units in a loop configuration
- Powering the Link/Repeaters
- Type of communication including format
- Selection of Fiber Optic Cable (FOC)

3.1 DATA RATE

Model 5845HRT and Model 5846HRT Link/Repeaters automatically support all data rates from 1600 bits per second to 2 Megabits per second (When the Data Coupling Switch is set to AC, Factory Default setting DC levels are supported when the switch is set to the DC position). No internal selection or setting is required. However, it is necessary that all connected IEDs be set at the same data rate.

3.2 OPTICAL BUDGET

The optical budget is a ratio of the receiver sensitivity to launched optical power, i.e. amount of light loss available from the transmitter to the receiver. It is calculated on a log scale so that a 3 dB loss is equal to half of the original power, 10 dB is one tenth of the original power, 20 dB is one hundredth, etc. Many different elements in the optical circuit can induce losses to the power of the signal. This attenuation must be taken into account when determining the distance that the signal can be transmitted. The major factor is the attenuation of the fiber optic cable. Cable attenuation is expressed as "X" dB per kilometer. Other factors of attenuation include FOC fittings (terminations, splitters, etc.) FOC diameter, and FOC aging.

Optical budget is the result of the expression:

$$\text{Optical Budget [dB]} = 10 \times \log_{10} \frac{\text{Receiver sensitivity } [\mu\text{w}]}{\text{Launch Power}}$$

Each Model 5845HRT or 5846HRT Link/Repeater has an available optical budget of 19.5 dB.

Each Model 5845SHRT or 5846SHRT Link/Repeater has an available optical budget of 19 dB.

3.2.1 Cable Attenuation Factors

The following cable factors must be applied as corrections to the optical budget.

3.2.1.1 Diameter

Multi-mode:

FOC of different diameters will vary the available optical budget of a system due to different FOC core diameters. The 19.5 dB optical budget is applicable to 62.5 μm diameter FOC. Table 1 shows the correction factors to use on the available optical budget for different diameter cable.

Table 1

FOC DIAMETER	FACTOR
50 μm	-3 dB
100 μm	+4 dB
200 μm	+7 dB

Single-mode:

19 dB of optical budget is available and is essentially consistent for fiber diameters.

3.2.1.2 Fittings

Adding additional splices, feed throughs, or patches to the FOC will add losses to the available optical budget. When using multi-mode Fiber Optic Cable terminated and supplied by DYMEC, optical connector losses can be ignored because the cable is tested after the terminations are added. If you are using fittings not supplied by DYMEC, you can get the optical budget loss information from their manufacturer(s).

3.2.1.3 Aging

As FOC ages, tiny cracks will form in the glass core of the fiber. These will cause the attenuation of the cable to increase. The optical emitters age over time causing a reduction in their optical launch power.

DYMEC suggests that a buffer be applied to the optical budget to assure proper operation of the unit over a 20-year life. A 2.5 dB to 3 dB loss factor is suggested to compensate for system aging over 20 years.

EXAMPLE

*FOC is 62.5/125 μ m multi-mode (DYMEC supplied)
100 kpsi rated 3 dB/km and 3 dB for aging
No other attenuating items in the circuit*

<i>Initial:</i>	<i>19.5 dB Optical Budget</i>
<i>Less:</i>	<i>3 dB aging</i>
<i>Less:</i>	<i>0 dB for other circuit attenuation fittings</i>
<i>Equals:</i>	<i>16.5 dB</i>
<i>Divided by:</i>	<i>3 dB/km</i>
<i>Equals:</i>	<i>5.5 km maximum distance of FOC between transmitter and receiver</i>

NOTE

FOC extends communication beyond normal EIA 422 or 485 Standard limits. The distance allowable between Link/Repeaters must be calculated using the factors listed above.

3.2.2 Extending the Distance

Should the distance between two devices exceed that calculated above, it is possible to insert a pair of Model 5845HRT or Model 5846HRT Link/Repeaters to function as stand alone repeaters, powered but not connected to an IED. Two Link/Repeaters are necessary, one for each fiber path. The Repeat Switch of each unit is placed in the ON position. Serving as a repeater only, the 9 Pin D connector should have a protective cover over the pins. If it is a single mode unit, pin 5 (signal common) should be tied to pin 6 (earth ground).

3.3 NUMBER OF REPEATS

In a loop configuration, the number of units that can be used as repeaters must be determined. A repeater is any unit that uses the repeat function of the Link/Repeater. All Slaves in a Master/Slave loop are considered repeaters. Three factors must be considered in calculating the maximum number of repeaters possible in a loop; the data rate (bits per second), the minimum required width of the original pulse echoed back to the Master, and the peak operating temperature.

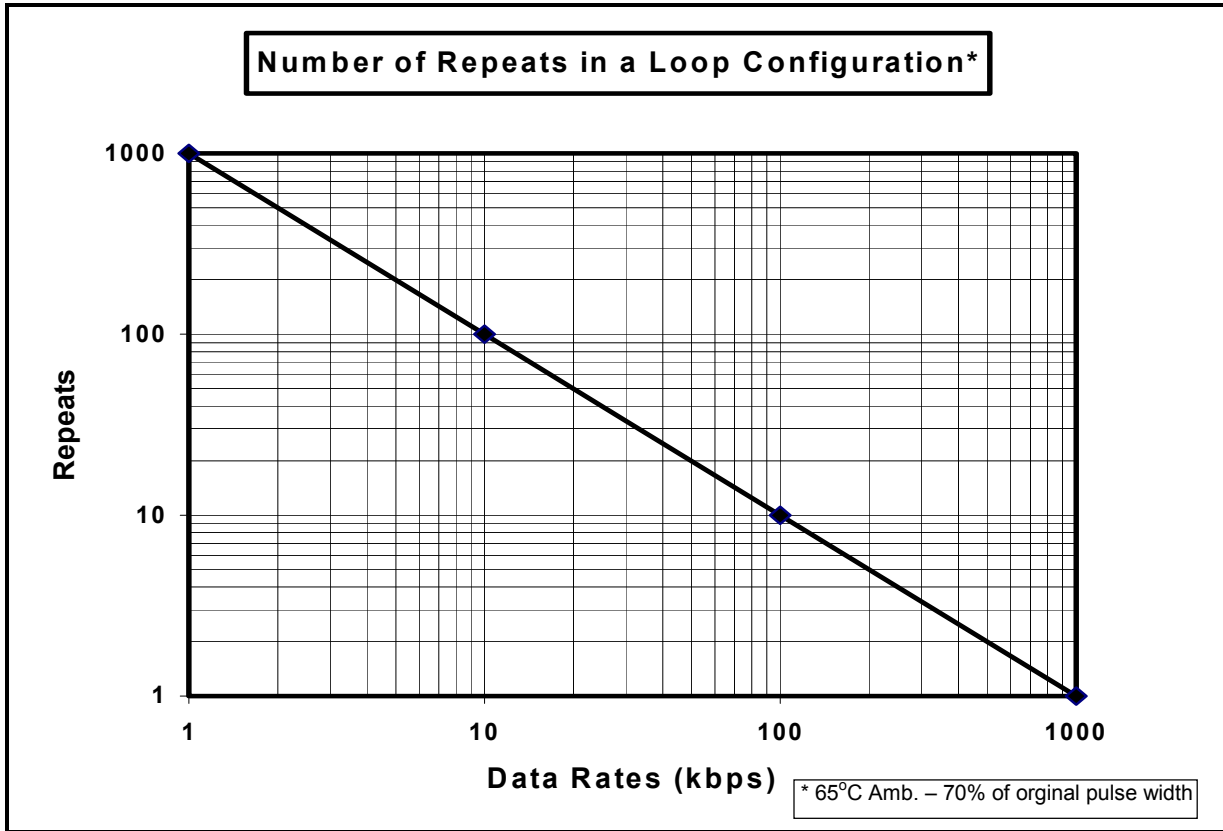

FIGURE 13. Number of Repeats

3.3.1 Effects of Data Rate

The number of repeaters is an inverse linear function to the data rate (more repeats at lower data rates). The data rate, or bits per second rate, determines what the original pulse width of each bit will be. The higher the data rate, the smaller the pulse width of each bit. As the signal passes through a repeater, any distortion effects on the data signal are greater at higher data rates due to smaller pulse widths than lower data rates.

3.3.2 Pulse Width Distortion

As the data signal is passed from repeater to repeater, there is a small change to the pulse width defined as pulse width distortion. The amount of change that is tolerable corresponds to the percentage of original pulse width required by a particular communication system design. Typically, a communication system requires the data word, or bit stream, that each Slave IED receives, match the signal originally generated by the Master, within some tolerance of pulse width distortion. High tolerance systems allow more pulse width distortion; therefore, more repeats are tolerated. Conversely, low tolerance systems allow fewer repeats in the loop.

Figure 13 shows the maximum number of repeats possible if 70% of the original pulse width is required by any IED in the loop. The acceptable percentage of the original pulse width is due to the requirements of

the IEDs. If more of the original pulse width is necessary or less is allowable, then the number found in Figure 13 can be modified. Table 2 shows the factors to be used to correct the number of repeats found in Figure 13 for such cases.

Table 2

% of Original Pulse	Multiply Factor
80%	.67
60%	1.33
50%	1.67

3.3.3 Temperature Effect

At peak operating temperature above 65°C, the maximum number of repeats should be de-rated by 20%. At higher temperatures, the distortion caused by each repeat increases, causing the maximum number of possible repeaters to go down.

EXAMPLE:

*Peak temperature of the system will be 70°C
 Running at 9600 bps
 60% of original pulse width possible*

*Initial: 100 repeats (from Figure 11)
 Less: 20% de-rate for 70°C
 Times: 1.33 for 60% pulse width
 Equals: $100 \times 0.8 \times 1.33 = 106$ repeats*

3.4 POWERING THE LINK/REPEATER

3.4.1 Model 5845HRT and 5845SHRT

Model 5845HRT may be powered through pin 9 on the D-connector or through a power connector on the side of the unit. The unit has an input voltage range of 9 to 15 Vdc through the 9 Pin (with pin 5 as GND) or through the power connector, and requires a maximum of 250 mA (340 mA for the 5845SHRT) over the entire operating temperature range. DYMEC's Model 4310S ac to dc power adapter is designed specifically for this purpose. It connects directly into a normal 110 volt power receptacle and has an operating temperature range of -0°C to +70°C.

3.4.2 Model 5846HRT and 5846SHRT

Model 5846HRT is designed with an internal universal regulated power supply for environments where unregulated ac or dc voltages are available. It accepts ac voltages in a range of 90 to 250 volts, 50 or 60 hertz, or dc voltages in a range of 90 to 250 volts. These power sources must be capable of supplying 45 mA (60 mA for the 5846SHRT) over the entire operating range. It is also possible to power the Model 5846HRT through pin 9 on the D-connector by applying 9 to 15 Vdc (pin 9 +, pin 5 GND). The current capacity of this power source must be 250 mA for the 5846HRT and 340 mA for the 5846SHRT.

NOTE

The Model 5846HRT can be ordered to accommodate 24 Vdc or 48 Vdc power.

Model 5846HRT is provided with a ground stud on the side of the case. An appropriate earth ground must be connected to this stud before power is applied to the unit. The internal surge withstand protection inside of the unit uses this ground stud as a sink for power surges. If the unit were not properly grounded, it may store charge until a path to ground becomes available. The lowest impedance to ground is recommended to avoid a ground potential rise.

WARNING

When installing a Model 5846HRT or 5846SHRT Link/Repeater, an earth Ground must be attached to the Ground Stud on the side of the case before connecting to power. Failure to follow this procedure may result in electrical shock to personnel.

3.5 LOGIC INVERSION SWITCH

The Logic Inversion Switch is located on the side of the unit and is standard on all Model 5845HRT and 5846HRT Link / Repeaters. The slide switch inverts the polarity and logic sense of all electrical transmit and receive signal states going to and from the 9 Pin D-connector. It is set toward the 9 Pin D-connector for the normal state (factory set default). When the slide switch is set toward the optics end of the unit, the protocol logic is in the inverted state.

Every 5845HRT or 5846HRT Link/Repeater in the same optical network must have the Logic Inversion Switch set to the same position so that the quiescent state results in no light in the fiber. This feature is required when optically interconnecting IEDs operating RS-232 to IEDs operating EIA 422 or 485; or connecting to some EIA 422 or 485 IEDs that employ non standard logic to signal communication; or for IEDs that employ line biasing that can cause the light to be on in the quiescent state; and can be used in all configurations.

Models 5845HRT and 5846HRT are designed to operate with no light in the fiber during the communication quiescent (quiet) state. Normal protocol for IEDs operating EIA 422 and 485 formats is implemented such that the quiescent state is achieved with the protocol at a logic low producing a potential low output. Occasionally, EIA 422 and 485 may have their output lines biased such that the "A" (+) is pulled high and the "B" (-) line is pulled low in the quiescent state. This situation will produce a "light on" situation in the fiber during the quiescent period. This condition is not desirable and the Logic Switch must be set in the INV position to compensate for this operation.

In addition, one can connect Dymec Models 5843HRT or 5844HRT (RS-232 Link / Repeaters) to the Models 5845HRT or 5846HRT and achieve RS-232 to EIA 422 or 485 format conversion directly in the fiber connection without the need of external converter devices. However, the following condition must be accounted for. In RS-232, the logic state is inverse to the physical layer, i.e. logic high produces a physical low. When connecting RS-232 protocol, this logic to physical layer inversion must be reversed or it will cause a "light on" situation in the quiescent state in the Model 5845HRT and 5846HRT. Again, the Logic Switch can be set in the INV position to correct this situation.

3.6 ECHO CONTROL FOR 2 WIRE EIA 485 MASTERS IN LOOP CONFIGURATIONS

Models 5845HRT and 5846HRT are designed to continuously listen, both electrically and optically, for data signals. Since the path is shared for transmit and receive, only one function may occur at any given interval in time. Models 5845HRT and 5846HRT are designed to give priority to data signals received optically to those being transmitted electrically assuming that the software logic is managing data traffic.

However, in loop configurations, a special situation occurs if the Master IED is operating 2 wire EIA 485 (HD). The echo of its transmissions can be received back to the Master so fast that it arrives before the

transmission is completed and data collision will occur. Echo control must be implemented for each 2 wire IED that can become a Master in any loop configuration.

A feature is provided to avoid this and is implemented as follows. The Master must apply a high potential (>2.4 v, but less than 30v) to pin 8 to disable the optical receiving circuitry of its Link/Repeater while transmitting. After the Master has completed transmitting plus a short time interval that allows for the echo to be completely blocked, the Master relinquishes control of the optical receive. The Master must then return pin 8 to a low potential (<0.8v) to re-enable its optical receiving circuitry. The Master is now ready to accept the response from its poll request. Use of this feature is not necessary for Slave units in loop configurations or in Point-to-Point, Optical Bus, nor Optical Star configurations. Typically, the software management sets an interval of null time before a polled Slave initiates its response and one-half to three quarters of this time interval can be used for the delay time before returning the Master to the optical receive enable state.

This feature is standard in all Model 5845HRT and 5846HRT Link/Repeaters.

3.7 OPTIONAL STATION POWER VOLTAGES

Models 5846HRT and 5846SHRT can be ordered for 24 Vdc to 48 Vdc operation. This modification is indicated by the suffix -L added to the Model number (i.e. 5846HRT-L). This option is Surge Withstand Protected to IEEE 1613.

3.8 TYPE OF COMMUNICATION

Model 5845HRT and Model 5846HRT Link/Repeaters support the following types of asynchronous communications:

- Simplex - Transmission only or receive only
- Half Duplex - Sequential transmit and receive
- Full Duplex - Simultaneous transmit and receive

	HD/FD Switch in FD Position			HD/FD Switch in HD Position		
	Simplex	Half Duplex	Full Duplex	Simplex	Half Duplex	Full Duplex
Point-to-Point: (Repeat Switch "OFF")	X	X	X	X	X	
Master/Slave Loop: Master (Repeat Switch "OFF")	X	X	X	X	X	
Master/Slave Loop: Slave (Repeat Switch "ON")	X	X		X	X	
Peer-to-Peer Loop: Master (Repeat Switch "OFF" and pin 7 "low")	X	X	X	X	X	
Peer-to-Peer Loop: Slave (Repeat Switch "OFF" and pin 7 "high")	X	X		X	X	

3.9 SELECTION OF FIBER OPTIC CABLE (FOC)

Fiber optical cable is available in several construction types simplex, duplex, and breakout. FOC is also available in various diameters and tensile strengths.

Simplex FOC is desirable for loop operations. It has one optical conductor and can be connected from the transmitter of one Link/Repeater to the receiver of the next Link/Repeater in the loop.

Duplex FOC has two optical conductors and is a convenient form when connecting two units Point-to-Point.

Breakout cable is a multiple fiber FOC that has extra strength members added and is suitable for burial and pulling in conduit. Breakout cable may be ordered with multiple pairs of fiber. For extreme conditions, it is also available with an armor jacket.

Tensile strength is important for longer life expectancy.

The following are the specifications of multi-mode FOC offered by DYMEC and are the recommended minimum standards for optimum performance.

		<u>Simplex</u>	<u>Duplex</u>	<u>Breakout</u>
Fiber Count		1	2	2
Fiber Material		Glass	Glass	Glass
Diameter	[mm]	3.0	3.0 x 6.5	7.0
Weight	[kg/km]	8.0	16.0	50
Tensile load- Short Term	[N]	500	1000	1200
Tensile load- Long Term	[N]	300	500	500
Minimum Bend Radius-With Load	[cm]	5	5	14
Minimum Bend Radius-No Load	[cm]	3	3	7
Crush Resistance	[N/cm]	750	750	2200
Impact Resistance	[Cycles]	1000	1000	2500
Flex Resistance	[Cycles]	7500	7500	2000
Operating Temperature	[°C]	-40° to +85°	-40° to +85°	-40° to +85°
Storage Temperature	[°C]	-55° to +85°	-55° to +85°	-55° to +85°

METRIC-TO-ENGLISH UNIT CONVERSIONS

		<u>MULTIPLY</u> <u>BY</u>			<u>MULTIPLY</u> <u>BY</u>		
Millimeters	→	Inches	0.03937	Kilograms	→	Pounds	2.2046
Centimeters	→	Inches	0.3937	Kg/Km	→	Pounds/1,000 Ft	0.67197
Meters	→	Feet	3.2808	Newtons	→	Pounds	0.22481
Kilometers	→	Feet	3280.8	N/Cm	→	Pounds/inch	0.57101
Kilometers	→	Miles	0.62137				

4. TESTING AND TROUBLE SHOOTING

4.1 TESTING

Models 5845HRT and 5846HRT lend themselves to easy installation and testing. Testing the units requires transmitting and receiving data or setting the Test Mode switch to ON while observing that the diagnostic LEDs are illuminating in the proper sequence.

To test whether a unit is transmitting and receiving correctly, insert a short fiber jumper between its T and R optical ports, transmit a signal and note that all four diagnostic LEDs should illuminate during communication (refer to Figure 5). If Test Mode is switched ON, instead of using a transmitted signal, TO and RO should illuminate.

To test the units in a loop configuration, two Link/Repeaters are required. Connect short Fiber jumper from the T optical port of one Link/Repeater to the R optical port of the other. Set the Repeat Switch for one of the units to ON and the other to OFF. The unit with the Repeat Switch in the OFF position is the Master. (Note: the FD/HD switch of this unit must be in the FD position for testing). Using the Master, transmit and receive (or use the Test Mode Switch in the ON position) through the other unit in the repeat mode. Observe that the diagnostic LEDs illuminate during communication (refer to Figure 5).

Note

If interconnecting EIA 485 optically to RS232, the NORM / INV switch must be in the INV position.

If the IED's design biases A (“+”) high and B (“-”) low (a “steady” illuminated TE light, with no data flowing, will indicate this), then the NORM / INV switch must be set to the INV position.

If a master of a master/slave loop is operating in the HD mode (EIA 485), refer to Section 3.6 for special system requirements for the control of the echo.

Models 5845SHRT and 5846SHRT (only)

When not connected to an IED and in the repeat mode, the Link/Repeater should have Chassis Ground (pin 6) connected to Signal Common (pin 5). If these pins are not tied together, noise could be induced into the fiber loop. This is also necessary when servicing an IED in order to keep the fiber loop and the Link/Repeater operational.

WARNING

The jumper connecting Chassis Ground and Signal Common should be disconnected before reconnecting Models 5845SHRT or 5846SHRT to an IED.

4.2 TROUBLE SHOOTING

- If the unit does not work properly, use the following check list:

- Is the unit properly powered?
 - Verify that the unit is receiving the correct power and the green "POWER" LED is illuminated.
 - If powered through the D-connector, make sure that + is on pin 9 and - on pin 6.
- Check that the diagnostic LEDs are responding to the optical and electrical activity.
- Is the unit mated properly to the IED? If an adapter is used, check that pins are connected correctly.
- Are the fiber cables connected properly? "T" to "R"; not "R" to "R" nor "T" to "T".
- Are the FD/HD switch, the Repeat switch, and NORM / INV switch set to the proper position for the application? (Are both FD / HD switch actuators set to the same position?)

NOTE

If the Link/Repeater is not connected directly to an IED, determine that the electrical signal received by the Link/Repeater is not corrupt. The Link/Repeater only repeats the signal it is given; it does not re-clock or re-generate the signal.

- Review the IED's software and protocols. Does the IED have physical "Handshaking" requirements and have the appropriate settings on the IED been made to compensate for these requirements?
- Consult factory.

NOTE

The diagnostic LEDs only illuminates when there is signal traffic and are not illuminated during signal "quiet" times. If during quiet time, TE and TO are illuminated, it suggests either a polarity reversal (pin 2 with pin 1) or that the IED is biased pulling the "A" (+) line with respect to the "B" (-) line. After checking the polarity on the connections, refer to Section 3.5.

The diagnostic LEDs may "flicker" when data is passing. This is normal operation.

NOTE

Link/Repeaters contain no serviceable parts. Opening the unit will void the warranty.

5. SPECIFICATIONS

5.1 Electrical and Optical Specifications (All Specifications over entire Operating Temperature Range)

Multimode	5845HRT	5846HRT
Optical Budget Typical	19.5 dB	19.5 dB
Output power Typical	-10.5 dBm peak	-10.5 dBm peak
Receiver Sensitivity Typical	-30 dBm peak	-30 dBm peak
	(62.5/125 Multimode)	(62.5/125 Multimode)
Wavelength	850nm	850nm
Connector Type	ST	ST
Compatible Fiber Type	Multi-Mode (50-200µm)	Multi-Mode (50-200µm)
Configuration (Switches)	HD/FD AC/DC Coupled Link/Repeat Logic Inversion Input Biasing Test Mode Enable Holdover	HD/FD AC/DC Coupled Link/Repeat Logic Inversion Input Biasing Test Mode Enable Holdover
Data Rate	DC or 1.6K to 2.0M bps	DC or 1.6K to 2.0M bps
Data Transmission	Asynchronous, simplex or Full Duplex	Asynchronous, simplex or Full Duplex
Transmission Distance	up to 5000 meters (62.5/125 Cable@3dB/km)	up to 5000 meters (62.5/125 Cable@3dB/km)
Bit Error Rate	10-E9 Max.	10-E9 Max.
Point to Point Latency	500 nsec Max	500 nsec Max
Repeat Latency	400 nsec Max	400 nsec Max
Electrical Parameters		
Inputs		
I/O Data Format	EIA RS422/485	EIA RS422/485
Data Connector	9 pin D-Type Female	9 pin D-Type Female
Input Impedance	750Ohms	750Ohms
Input Voltage	+12 V to -7 Volts Max +/- 6V Differential	+12 V to -7 Volts Max +/- 6V Differential
Outputs		
Output Impedance	250 Ohms	250 Ohms
Driver Output	50mA	50mA
Ambient Temperature		
Operating Temperatures	-40 to +85 C	-40 to +85 C
Storage Temperature	-40 to +85 C	-40 to +85 C
Power Required	3.0 Watts 250 mA @12V	6.0 Watts 45 mA @ 90-250 V 250 mA @ 18-60 V
Power Dissipation BTU/H	10 BTU	20 BTU
Weight	9 Ozs.	17 Ozs.
Dimensions Inches	2.0W X 5.1L X 1.3H	4.1W X 5.1L X 1.3H
Indicators	Power Transmit Fiber Transmit Electrical Receive Fiber Receive Electrical	Power Transmit Fiber Transmit Electrical Receive Fiber Receive Electrical

Electrical and Optical Specifications (All Specifications over entire Operating Temperature Range)**Single-Mode****5845SHRT****5846SHRT**

Optical Budget Typical	19 dB	19 dB
Output power Typical	-14.5 dBm peak	-14.5 dBm peak
Receiver Sensitivity Typical	-33.5 dBm peak (9/125 Multimode)	-33.5 dBm peak (9/125 Multimode)
Wavelength	1300nm	1300nm
Connector Type	ST	ST
Compatible Fiber Type	Single-Mode (9-13µm)	Single-Mode (9-13µm)
Configuration (Switches)	HD/FD AC/DC Coupled Link/Repeat Logic Inversion Input Biasing Test Mode Enable Holdover	HD/FD AC/DC Coupled Link/Repeat Logic Inversion Test Mode Input Biasing Enable Holdover
Data Rate	1.6K to 2.0M bps	1.6K to 2.0M bps
Data Transmission	Asynchronous, simplex or Full Duplex	Asynchronous, simplex or Full Duplex
Transmission Distance	up to ~30K meters (9/125 Cable@0.3dB/km)	up to ~30K meters (9/125 Cable@0.3dB/km)
Bit Error Rate	10-E9 Max.	10-E9 Max.
Point to Point Latency	500 nsec Max	500 nsec Max
Repeat Latency	400 nsec Max	400 nsec Max

Electrical Parameters**Inputs**

I/O Data Format	EIA RS422/485	EIA RS422/485
Data Connector	9 pin D-Type Female	9 pin D-Type Female
Input Impedance	750Ohms	750Ohms
Input Voltage	+12 V to -7 Volts Max +/- 6V Differential	+12 V to -7 Volts Max +/- 6V Differential

Outputs

Output Impedance	250 Ohms	250 Ohms
Driver Output	50mA	50mA

Ambient Temperature

Operating Temperatures	-40 to +70 C	-40 to +70 C
Storage Temperature	-40 to +85 C	-40 to +85 C
Power Required	6.0 Watts 340 mA @12V	8.0 Watts 60 mA @ 90-250 V 340 mA @ 18-60 V
Power Dissipation BTU/H	14 BTU	27 BTU
Weight	9 Ozs.	17 Ozs.
Dimensions Inches	2.0W X 5.1L X 1.3H	4.1W X 5.1L X 1.3H
Indicators	Power Transmit Fiber Transmit Electrical Receive Fiber Receive Electrical	Power Transmit Fiber Transmit Electrical Receive Fiber Receive Electrical

5.2 Mechanical Dimensions of the 5845HRT and 5845SHRT

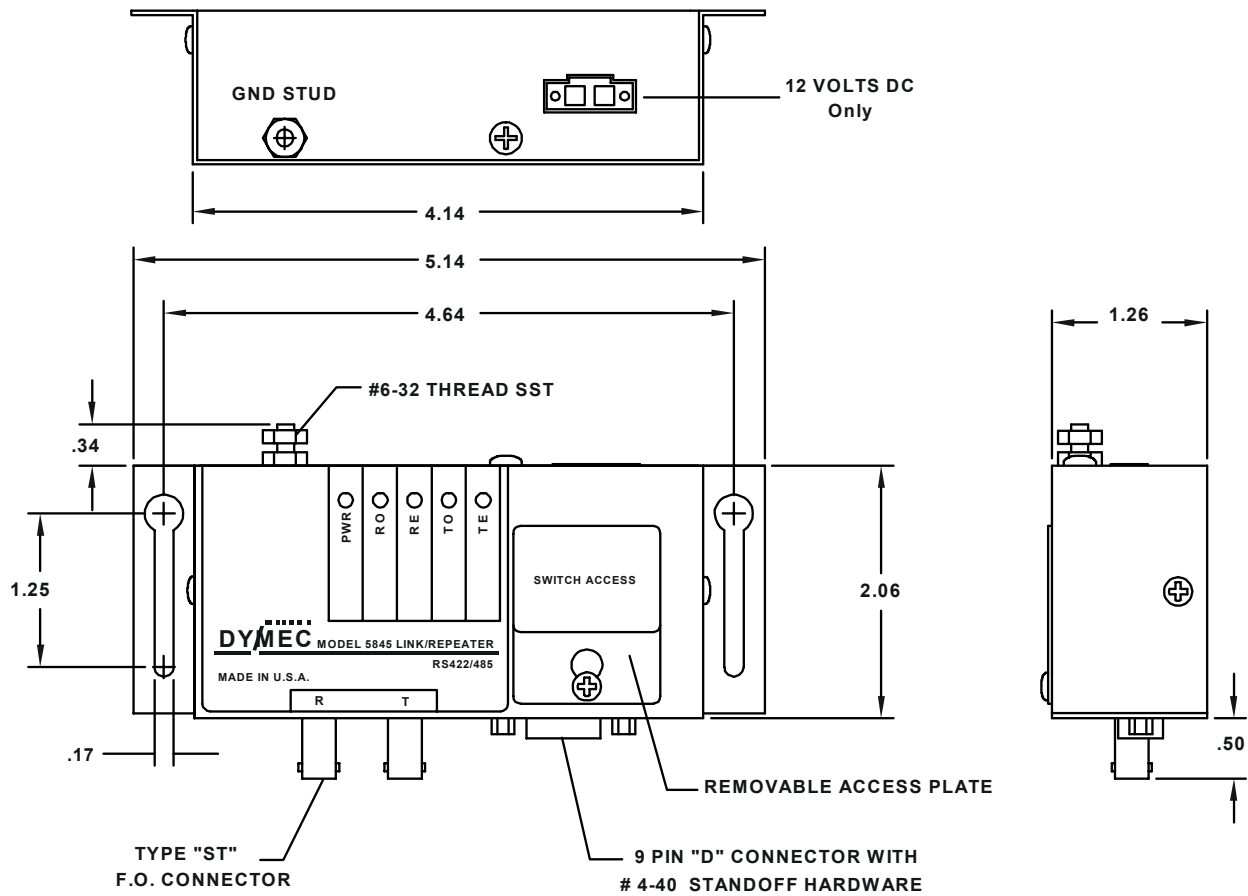

NOTE: DIMENSIONS ARE IN INCHES.

5.3 Mechanical Dimensions of the 5846HRT and 5846SHRT

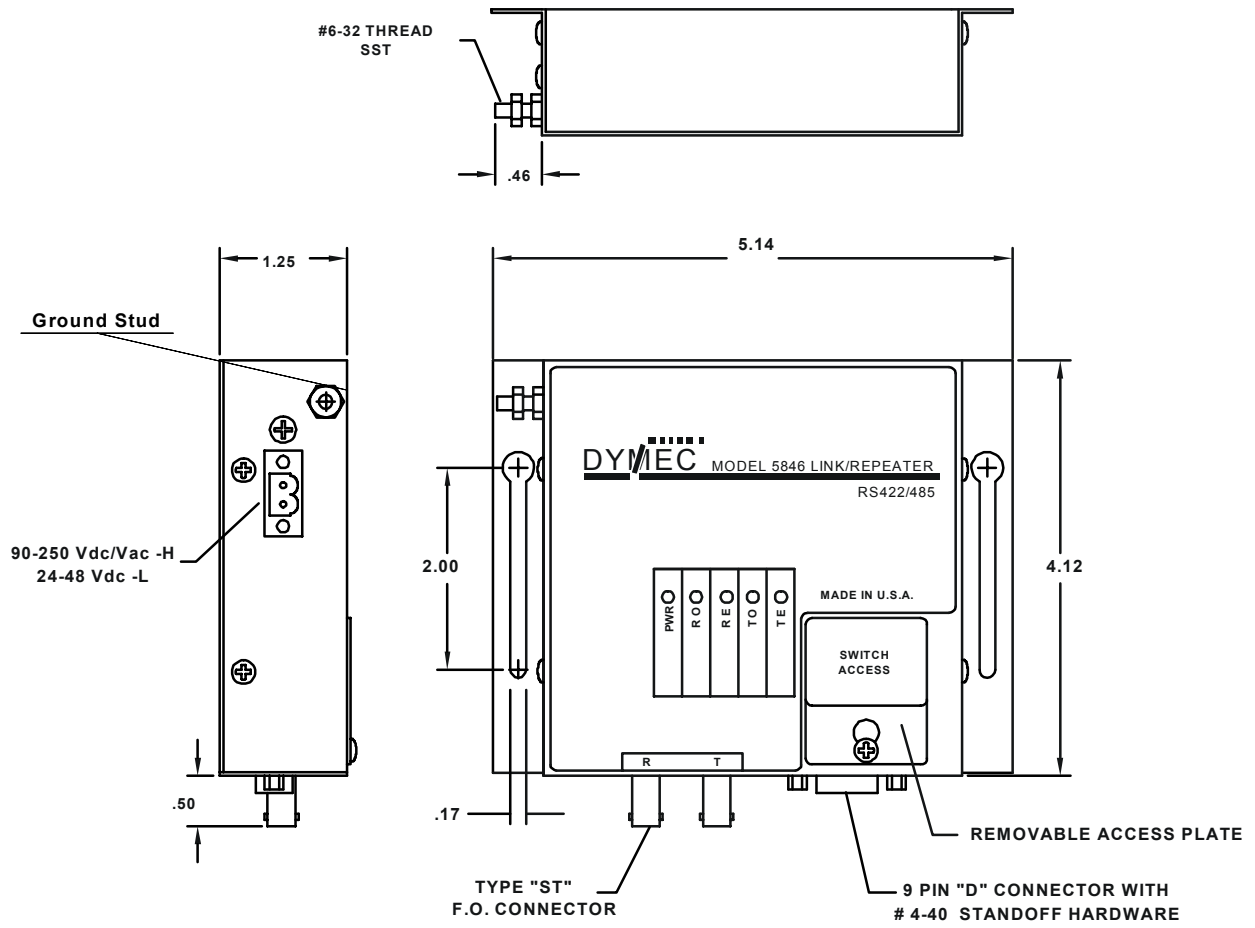

6.0 Ordering Information:

LINK/REPEATERS

Part Number			
Model	EIA Std	Fiber Type	Input Power Rating
5843HRT	RS 232/TTL	Multi-Mode	9 - 15 Vdc
5844HRT-H	RS 232/TTL	Multi-Mode	90-250 Vdc/ 90-250 Vac
5844HRT-L	RS 232/TTL	Multi-Mode	24-48 Vdc
5845HRT	RS 422/485	Multi-Mode	9 - 15 Vdc
5846HRT-H	RS 422/485	Multi-Mode	90-250 Vdc/ 90-250 Vac
5846HRT-L	RS 422/485	Multi-Mode	24-48 Vdc
5843SHRT	RS 232/TTL	Single-Mode	9 - 15 Vdc
5844SHRT-H	RS 232/TTL	Single-Mode	90-250 Vdc/ 90-250 Vac
5844SHRT-L	RS 232/TTL	Single-Mode	24-48 Vdc
5845SHRT	RS 422/485	Single-Mode	9 - 15 Vdc
5846SHRT-H	RS 422/485	Single-Mode	90-250 Vdc/ 90-250 Vac
5846SHRT-L	RS 422/485	Single-Mode	24-48 Vdc

ACCESSORIES

Model	Description
4310-S	125 Vac to 12 Vdc Power adapter for Models 5941HRT, 5941SHRT, 5843HRT, 5843SHRT, 5845HRT and 5845SHRT
Bulletin UM5843	User Manual for Models 5843HRT, 5843SHRT, 5844HRT and 5844SHRT
Bulletin UM5845	User Manual for Models 5845HRT, 5845SHRT, 5846HRT and 5846SHRT
Bulletin UM5941	User Manual for Models 5941HRT, 5941SHRT, 5942HRT and 5942SHRT
Bulletin UMCH43	User Manual for Model CH43HRT
Bulletin UMCH45	User Manual for Model CH45HRT
5753A-XXXX	Simplex Multi-Mode Fiber Optic Cable (62.5/125 μ m), 100 KPSI. Suitable for use in cable troughs, conduit, and outdoor applications.
5754A-XXXX	Duplex Multi-Mode Fiber Optic Cable (62.5/125 μ m), 100 KPSI. Suitable for use in cable troughs, conduit, and outdoor applications.
5756A-XXXX	Breakout Duplex Multi-Mode Fiber Optic Cable (62.5/125 μ m), 100 KPSI. Suitable for use in cable troughs, conduit, and outdoor applications and direct burial, underground burial, lashed and building riser.
Terminations	Cable cut to length, Terminated with ST Type Multi-Mode Fiber Optic Connectors and Complete Assembly Tested

XXXX = the length of the fiber optic cable in Meters (note: order only in full meters and not a fraction thereof) 1 Meter = 3.281 Feet



25 Commerce Way #1, North Andover, MA 01845
978-688-8807 • FAX 978-688-8771

www.dymec.com

READER'S COMMENTS

We invite your comments and welcome suggestions to make this manual more useful.

Bulletin # _____ Rev # _____ Today's Date _____

GENERAL COMMENTS:

	Improve	Acceptable	Good	Excellent
Contents	<input type="checkbox"/>	<input type="checkbox"/>	<input type="checkbox"/>	<input type="checkbox"/>
Organization	<input type="checkbox"/>	<input type="checkbox"/>	<input type="checkbox"/>	<input type="checkbox"/>
Accuracy	<input type="checkbox"/>	<input type="checkbox"/>	<input type="checkbox"/>	<input type="checkbox"/>
Clarity	<input type="checkbox"/>	<input type="checkbox"/>	<input type="checkbox"/>	<input type="checkbox"/>
Completeness	<input type="checkbox"/>	<input type="checkbox"/>	<input type="checkbox"/>	<input type="checkbox"/>
Example/Illustrations	<input type="checkbox"/>	<input type="checkbox"/>	<input type="checkbox"/>	<input type="checkbox"/>
Referencing/Indexing	<input type="checkbox"/>	<input type="checkbox"/>	<input type="checkbox"/>	<input type="checkbox"/>
Readability	<input type="checkbox"/>	<input type="checkbox"/>	<input type="checkbox"/>	<input type="checkbox"/>

DETAILED COMMENTS: (Please be specific; i.e.: correct, expand, etc.)

Page No. Comments

_____	_____
_____	_____
_____	_____
_____	_____

Other suggestions for improving this document: _____

Compared to other manufacturers of a similar product, how would you rate this document?

Superior	Comparable	Inferior	Don't Know
<input type="checkbox"/>	<input type="checkbox"/>	<input type="checkbox"/>	<input type="checkbox"/>

Comments: _____

Comments concerning your specific application: _____

Name: _____

Title: _____

Company: _____

Address: _____

City/State/Zip: _____

Telephone/FAX: _____

Please FAX or mail this sheet to the address listed below. Attn: Document Supervisor



25 Commerce Way #1, North Andover, MA 01845
978-688-8807 • FAX 978-688-8771

www.dymec.com