

# Industrial Fiber Optic Link/Repeaters<sup>®</sup>

Models 5843HRT and 5844HRT  
Models 5843SHRT and 5844SHRT

## User Manual

**UM5843**  
REV AD



25 Commerce Way #1 North Andover, MA 01845  
(978) 688-8807 • FAX (978) 688-8771  
[www.dymec.com](http://www.dymec.com)

## ***Warnings, Cautions, and Notes Used in this Publication***

### **WARNING**

Warning notices are used in this publication to emphasize that hazardous voltages, currents, or other conditions that could cause personal injury exist in this equipment or may be associated with its use.

In situations where inattention could cause either injury or damage to equipment, a Warning notice is used.

### **CAUTION**

Caution notices are used where equipment malfunction is possible if care is not taken.

### **NOTE**

### **APPLICATION NOTE**

**Notes and Application Notes call attention to information that is especially significant to understanding and operating the equipment.**

This document is based on information available at the time of its publication. While efforts have been made to be accurate, the information contained herein does not purport to cover all details or variations, or to provide for every possible contingency in connection with installation, operation, or maintenance. DYMEC assumes no obligation of notice to holders of this document with respect to changes subsequently made.

DYMEC makes no representation or warranty, expressed, implied, or statutory with respect to, and assumes no responsibility for the accuracy, completeness, sufficiency, or usefulness of the information contained herein. No warranties of merchantability or fitness for purpose shall apply.

**Permission is granted to make a reasonable number of copies of this document for the use within the organization that has purchased the equipment.**

- Link/Repeater is used exclusively to describe DYMEC's unique family of Fiber Optic Data Links.

# Table of Contents

	<u>Page</u>
<b>1. Introduction</b>	<b>1-1</b>
1.1 Definitions	1-1
1.2 Model 5843HRT and 5844HRT Link/Repeaters	1-5
1.2.1 9 Pin Data Port D-Connector	1-5
1.2.2 DTE/DCE Switch	1-6
1.2.3 Repeat Switch	1-6
1.2.4 Input Coupling Switch	1-6
1.2.5 Handshaking Switch	1-6
1.2.6 Drive Current Pin 8 Switch	1-7
1.2.7 Test Mode Switch	1-7
1.2.8 Optical Ports	1-7
1.2.9 Diagnostic LEDs	1-8
1.2.10 Power Connections	1-8
1.2.11 Peripheral Equipment	1-9
<b>2. Configurations, Operation, and Installation</b>	<b>2-1</b>
2.1 Point-to-Point Configuration	2-1
2.2 Loop Operation - Master/Slave Configuration	2-5
2.3 Loop Operation - Peer-to-Peer Configuration	2-7
<b>3. Applications</b>	<b>3-1</b>
3.1 Data Rate	3-1
3.2 Optical Budget	3-1
3.2.1 Cable Attenuation Factors	3-1
3.2.2 Extending the Distance	3-2
3.3 Number of Repeats	3-3
3.3.1 Effects of Data Rate	3-3
3.3.2 Pulse Width Distortion	3-3
3.3.3 Temperature Effect	3-4
3.4 Powering the Link/Repeater	3-4
3.4.1 Model 5843HRT or 5843SHRT	3-4
3.4.2 Model 5844HRT or 5844SHRT	3-4
3.5 Optional Station Power Voltages	3-6
3.6 Type of Communication	3-6
3.7 Selection of Fiber Optic Cable	3-6
<b>4. Testing and Troubleshooting</b>	<b>4-1</b>
4.1 Testing	4-1
4.2 Troubleshooting	4-1
<b>5. Specifications</b>	<b>5-1</b>
5.1 Electrical and Optical Specifications	5-1
5.2 Mechanical Dimensions of the 5843HRT or 5843SHRT	5-3
5.3 Mechanical Dimensions of the 5844HRT or 5844SHRT	5-4
<b>6. Ordering Information</b>	<b>6-1</b>



## 1. INTRODUCTION

DYMEC Models 5843HRT, 5843SHRT, 5844HRT and 5844SHRT are data communication Link/Repeaters which allow the replacement of copper wire with fiber optic cable. Link/Repeaters simply convert electrical signals to light for transmission, then, when received, convert the light signals to back electrical. This is done for RS-232 or TTL formats.

Link/Repeaters are passive to software protocol. They are not addressable in communication protocols and do not provide any control logic capability to support communication protocols. Link/Repeaters are designed with several features that allow easy installation and flexibility in configuring for various communication systems.

Models 5843HRT and 5844HRT are similar except for the method in which they are powered.

Models 5843SHRT and 5844SHRT have the same features and functionality described for the Models 5843HRT and 5844HRT respectively with the exception that they have single mode optics for use with single mode fiber cable.

### NOTE

**This manual makes reference to the Model 5843HRT and Model 5844HRT when describing features and functionality of the Link/Repeaters. These descriptions generally apply to the Model 5843SHRT and Model 5844SHRT as well. When different, a specific reference is made identifying the particular model(s) and their variation.**

The User should read this manual to fully understand how to use the many features of the Link/Repeaters in an effective communication system.

### 1.1 DEFINITIONS

The following terms are used in this manual:

#### **IED:**

An IED is any intelligent electrical device capable of RS-232 and/or TTL data communications, such as; a computer, RTU, PLC, "smart" meter, relay, etc. The IED must have resident software or firmware that manages the data communication logic, including protocol (formatting and timing), addressing capability (if required), control logic software "handshaking", and scheduling.

#### **Point-to-Point Configuration:**

Two Link/Repeaters connected directly to each other.

#### **Master/Slave Loop Configuration:**

More than two Link/Repeaters connected together where the FOC connects the T optical port of one device to the R optical port of the next unit in the loop. One IED is designated as the Master and controls all the communication and the other IED's act as Slaves and respond only when specifically polled by the Master.

#### **Peer-to-Peer Loop Configuration:**

More than two Link/Repeaters connected together where the FOC connects the T optical port of one device to the R optical port of the next unit in the loop. Each IED has the capability of becoming loop Master as allowed by the controlling software.

#### **Echo:**

The return of the Master's transmission back to the Master after traveling around the optical loop.

#### **Optical Bus Configuration:**

More than two Link/Repeaters connected together in a manner where the Master's transmission is heard by all IED's and there is no returning echo of this transmission.

**Optical Star Configuration:**

More than two Link/Repeaters connected together in a “hub and spoke” topology where the Master’s transmission is heard by all IED’s and only the Master hears the polled Slave’s response and there is no returning echo of the transmissions.

**Master:**

The Master is the IED that controls the loop in a Master/Slave loop. This IED is responsible for the control of the loop, the polling of the Slaves for information, and the prevention of data collisions. All loop communication is echoed back to and stops at the Master. The Master’s Repeat Switch is always in the “OFF” position.

**Slave:**

A Slave is an IED that is passive in a Master/Slave loop. A Slave’s communication is under the control of the Master, and should be controlled to prevent data collision in the loop. All communication generated by the Master will be repeated through each Slave and back to the Master. A Slave’s Repeat Switch is always in the “ON” position.

**Peer:**

Peers are IED’s that have equal status and each may Master the loop when allowed by the software. A Peer’s Repeat Switch is always in the “OFF” position and a Peer IED controls pin 8 of its Link/Repeater in order to obtain status as loop Master.

**FOC:**

Fiber Optic Cable.

**Single-mode:**

Single-mode fibers generally have diameters of 5µm to 13µm. Because of this small core, only one axial path for light propagation is available through the fiber. The optics required to drive single-mode fiber have to be highly focused so that minimum dispersion occurs. Though requiring more expensive optic emitters, the benefit is that longer transmission distances (< 35 km) can be achieved.

**Multi-mode:**

Multi-mode fibers have core diameters of 50µm and larger. This larger core allows the light rays to be propagated along several different paths down the fiber. The different paths include an axial component as well as reflected components. Multi-mode units are economical and effective for transmission over distances up to 6 km.

**Repeat Switch:**

The Repeat Switch enables (REP) or disables (OFF) the repeater function of the Link/Repeater.

**DTE/DCE Switch:**

Each Link/Repeater is provided with this switch (2 position) to easily adapt the device to either the DTE or DCE configuration of the equipment which it connects.

**Data Coupling Switch:**

Each Link/Repeater is provided with this switch to easily adapt the device for either DC or AC electrical Input data coupling. With AC data coupling the minimum input data rate is 1200 baud with DC data coupling there is no minimum input data rate but a signal stuck on the input will lock up a loop, bussed or star network.

**Pin 8 Output Option Switch: (Switch 5B)**

Models 5843 and 5844 Links are provided with this switch to allow users who require more drive current on the TTL output pin (pin 8) to accomplish this. Selections are High or Low. Consideration should be given that the current value selected is appropriate for the input of the device being connected to this data channel.

**Test Mode Switch:**

Models 5843 and 5844 are provided with this switch to allow users who wish to test the fiber connections of the link with a built in diagnostic mode. This mode sends a 100Hz signal out the transmit port as well as looping back the copper port (pins 2 and 3) for diagnostic purposes.

**Handshaking Switch:**

Each Link/Repeater is provided with this switch to easily adapt the device for use where the connected IED needs to see active electrical levels on certain handshaking pins but does not require full handshaking implementation.

**Simplex Communication:**

Transmit only or receive only communications.

**Half Duplex Communication:**

Sequential transmit and receive communications.

**Full Duplex Communication:**

Simultaneous transmit and receive communications.

**T:**

Transmit optical port.

**TE:**

Diagnostic LED that illuminates when the Link/Repeater is receiving an electrical transmit from its IED.

**TO:**

Diagnostic LED that illuminates when the Link/Repeater is transmitting a signal optically.

**R:**

Receive optical port.

**RE:**

Diagnostic LED that illuminates when the Link/Repeater is delivering a received optical signal electrically to the IED.

**RO:**

Diagnostic LED that illuminates when the Link/Repeater is receiving a signal optically.

**Optical Budget:**

The optical budget is expressed in dB and is the amount of light loss tolerated for communication. The total distance between two devices that a signal can be transmitted is determined by subtracting all the losses of the circuit from the optical budget. Various factors in the optical circuit attenuate the light transmission and must be accounted for to assure a reliable optical circuit. Key factors include cable attenuation (expressed as dB per unit length), cable aging, and cable fittings (terminations, splitters, etc.).

**Non Return to Zero (NRZ):**

This type of encoding scheme does not require the voltage potential of each data bit to return to the zero potential. No clock or timing recovery is provided with this type of communication except in the start and stop bits usually found on each data word.

**Return to Zero (RZ):**

This type of encoding scheme requires the voltage potential of each data bit to return to the zero potential. This allows timing recovery with each bit instead of just the start and stop bits of the data word.

**Number of Repeats:**

The Number of Repeats is the number of Link/Repeaters that may be connected in a loop configuration. The sum of Slaves in a Master/Slave loop is the number of repeats for that type of loop. The number of Peers minus one is the number of repeats in a Peer-to-Peer loop.

**Asynchronous Communication:**

This type of communication does not transmit a separate clock signal with the data signal. Link/Repeaters support asynchronous communication. A communication scheme where the clock needs to be transmitted (Synchronous Communication) is not supported unless the data and clock are transmitted together on the same pin.

**1.2 MODEL 5843HRT AND MODEL 5844HRT LINK/REPEATERS**

**NOTE**

**Link/Repeaters contain no serviceable parts. Opening the unit will void the warranty.**

Each Link/Repeater consists of the following elements shown in Figure 1.

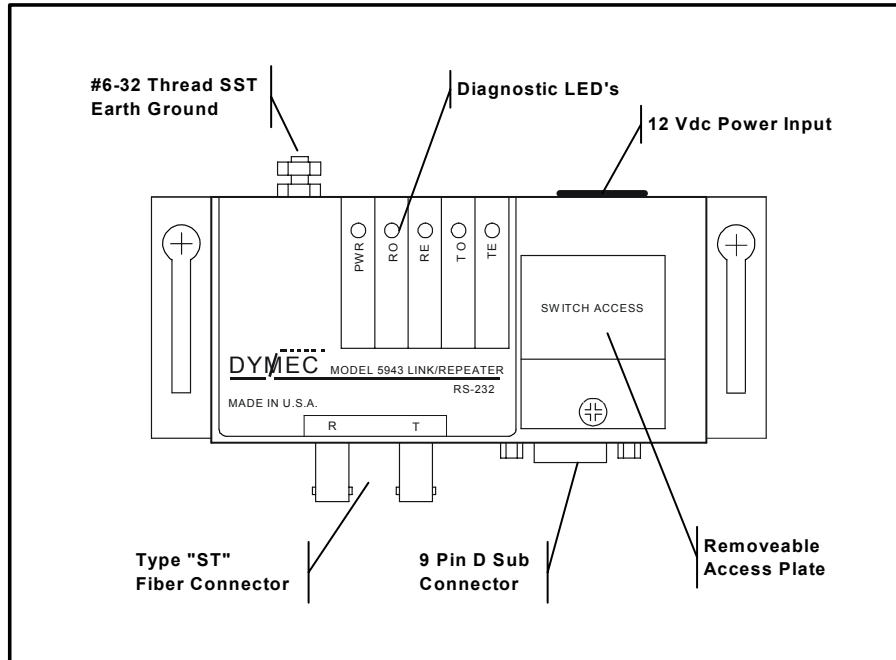

**FIGURE 1. Elements of the Link/Repeater**

**1.2.1 9 Pin Data Port D-connector**

The Link/Repeater connects directly to an IED's RS-232 or TTL communication port. The pin out configuration of the Link/Repeater is shown in Figure 2. If the IED's port is not a 9 Pin D-connector or if the IED's pin out configuration differs, an adapter is required.

<b>DTE MODE</b>	DCE DTE ↓	<b>DCE MODE</b>	DCE DTE ↑
<ul style="list-style-type: none"> <li>• 1 Chassis Ground</li> <li>• 2 Transmitted Data (Link Input)</li> <li>• 3 Received Data (Link Output)</li> <li>• 4 <i>No Connection</i></li> <li>• 5 Signal Common</li> <li>• 6 (+5 Vdc Output)</li> <li>• 7 <i>Repeat Enable / Disable</i></li> <li>• 8 TTL Output</li> <li>• 9 9 to 15 Vdc Input</li> </ul>		<ul style="list-style-type: none"> <li>• 1 Chassis Ground</li> <li>• 2 Received Data (Link Output)</li> <li>• 3 Transmitted Data (Link Input)</li> <li>• 4 <i>No Connection</i></li> <li>• 5 Signal Common</li> <li>• 6 (+5 Vdc Output)</li> <li>• 7 <i>Repeat Enable / Disable</i></li> <li>• 8 TTL Output</li> <li>• 9 9 to 15 Vdc Input</li> </ul>	

**Figure 2 Data Port Pin Assignments**

### 1.2.2 DTE/DCE Switch (Two Position Switch)

The DTE/DCE Switch on the Link/Repeater switches the functions of pins 2 and 3 to accommodate the IED configuration as DTE or DCE. This is a 2 position switch and both actuators must be set for the Link/Repeater to work properly.

**DTE:** Data Terminal Equipment. By RS-232 standards, equipment designed as DTE transmits data out of pin 2 on a 9 Pin D-connector and receives data on pin 3.

**DCE:** Data Communication Equipment. By RS-232 standards, equipment designed as DCE transmits data out of pin 3 on a 9 Pin D-connector and receives data on pin 2.

### 1.2.3 Data Coupling Switch

The Data Coupling switch selects the electrical input conditioning, the AC position selects capacitively coupled, the DC position is directly coupled.

**AC:** AC coupling has a minimum incoming data requirement of 1200 baud due to the capacitive coupling. This option blocks DC electrical levels should the device connected fail and 'stick in a high level'. There is a 35 mS timeout for "stuck" output pins, after this time out the link returns to LED off state.

**DC:** DC coupling allows DC logic levels to be transmitted over the fiber network, care must be taken to guarantee that when any device stops transmitting packets that the input level returns to a state that allows the T receptacle (emitter) to turn off. If it does not and the IED is part of a loop, bussed or star network, the first device to transmit blocks all other devices on the network from transmitting. \*Single-Mode units cannot be DC coupled.

### 1.2.4 Repeat Switch

The Repeat Switch enables the repeater function in the "ON" position and disables it in the "OFF" position.

**ON:** The repeater function available in the Link/Repeater is enabled. This function converts the optical signal received on the R optical port to an electrical signal and delivers this signal to the appropriate pin of the 9 Pin connector, as well as, re-transmits the signal optically out the Link/Repeater's T optical port.

**OFF:** The repeater function available in the Link/Repeater is disabled. The Link/Repeater converts the optical signal received on the R optical port to an electrical signal and delivers this signal to the appropriate pin of the 9 Pin connector, and does not re-transmit the signal optically out the Link/Repeater's T optical port.

### 1.2.5 Handshaking Switch 4B:

The Handshaking Switch outputs 5 Vdc on a standard handshaking pin in the "ON" position and disconnects the pins it in the "OFF" position.

**ON:** Pin 6 (Data Set Ready) of the Link/Repeater output 5 Vdc. This signal is used by devices requiring handshaking signals to indicate the readiness of the connected devices to receive data.

**OFF:** Pin 6 of the Link/Repeater is not connected.

### 1.2.6 Pin 8 Current Output Option Switch 5B:

Models 5843 and 5844 Links are provided with this switch to allow users select one of 2 output source drive current values for the TTL output pin (pin 8). Selections are 10ma (207 Ohm) or 20ma (67 Ohm). Consideration should be given that the current value selected is appropriate for the input of the device being connected to this data channel.

### 1.2.7 Test Mode Option Switch 3B:

Models 5843 and 5844 Links are provided with this switch to allow users who wish to test the fiber connections of the link with a built in diagnostic mode. This mode sends a 100Hz signal out the transmit port as well as looping back the copper port (pins 2 and 3) for diagnostic purposes.

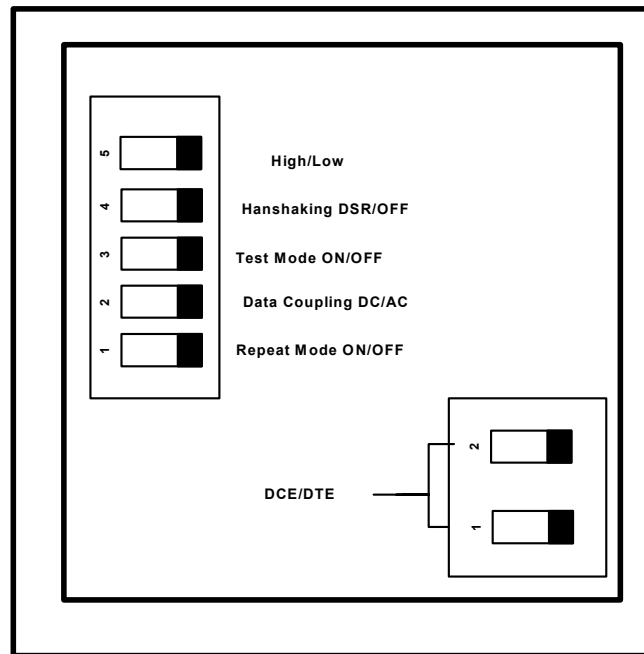

FIGURE 4. Switch Settings

### 1.2.8 Optical Ports

There are two optical ports, T and R. The T optical port transmits data signals optically to the next Link/Repeater. The R port receives the optical data signal from another Link/Repeater's T optical port. Each port is fitted with an "ST" type receptacle for attaching the FOC.

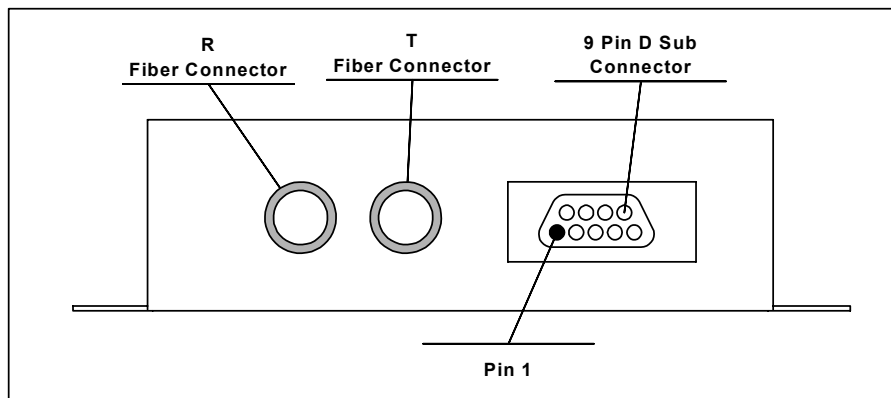

Figure 3 Optical Ports and Electrical Port

### 1.2.9 Diagnostic LEDs

Each Link/Repeater is equipped with four diagnostic LEDs. They represent the electrical transmit (TE), optical transmit (TO), electrical delivery (RE), and optical receive (RO) paths. These LEDs, when illuminated, show that the appropriate path is active. When the Link/Repeater is transmitting, both TE and TO LEDs will illuminate to show the transmit path active. When the Link/Repeater is receiving light signals, both RO and RE LEDs will illuminate. If the unit is in the repeat mode and receiving light, the RO, RE and TO LEDs will illuminate because the signal is being re-transmitted out the optical port, as well as, being delivered to the D-connector. LEDs only illuminate when the path is active; powering of the unit does not illuminate the LEDs unless their path is active. When data is present on the paths, the LEDs may "flicker"; this is normal. The diagnostic LEDs may be used for trouble shooting by observing that the illumination of the LEDs corresponds with activity in the unit. See Figure 5 for LED patterns and signal paths.

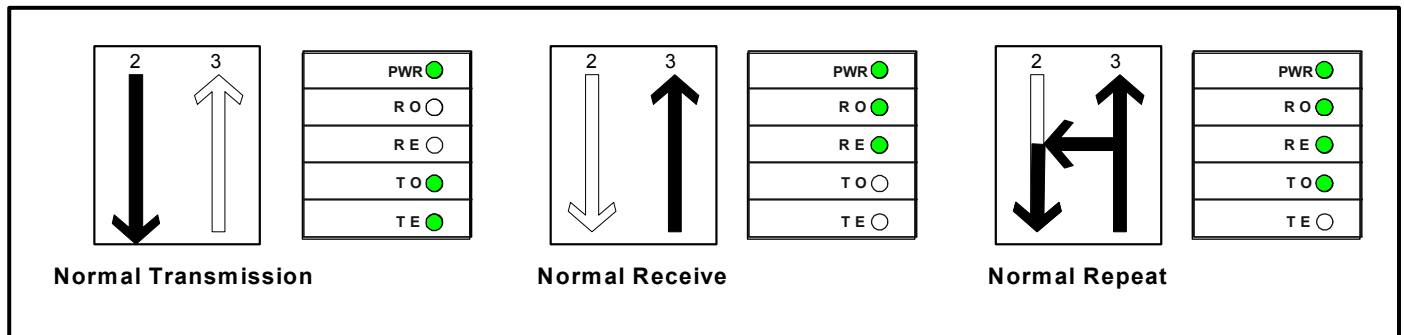

FIGURE 5. Diagnostic LED patterns and signal paths

#### NOTE

The LEDs only illuminate when there is signal traffic and are not illuminated during signal "quiet" times.

The LEDs may "flicker". This is normal operation.

### 1.2.10 Power Connections

#### 1.2.10.1 Powering Model 5843HRT

Model 5843HRT may be powered either through pin 9+ (and pin 5-) of the 9 Pin D-connector or the external connector located on the back of the unit:

- 1) When powering the 5843HRT via pin 9 of its D-connector, the IED must supply at least 250 mA (340mA for the 5843SHRT). The voltage should be regulated and within a range of 9 to 15 Vdc.
- 2) When powering the 5843HRT via its external connector, DYMEC offers a 110 Vac to 12 Vdc adapter (Model 4310S) that is designed specifically to plug into this connector. Model 4310S assures reliable power over the temperature range of 0°C to + 70°C.

**CAUTION**

Regardless of the power connection used, Model 5843HRT requires 250 mA (340 mA for the 5843SHRT) within a range of 9 to 15 VDC. An inadequate power supply not capable of supplying 250 mA over the entire operating temperature range may cause the Link/Repeater to malfunction.

1.2.10.2 Powering the Model 5844HRT

Model 5844HRT may be powered either through pin 9+ (and pin 5-) of the 9 Pin D-connector or the power connector located on the side of the unit:

- 1) When powering Model 5844HRT via pin 9 of its D-connector, the IED must supply at least 250 mA (340 mA for the 5844SHRT). The voltage should be regulated and within a range of 9 to 15 Vdc.
- 2) Model 5844HRT has an internal regulated power supply that may be connected directly to ac or dc station power. The station power may be 90 to 250 Vac, 50/60 Hz or 90 to 250 Vdc. The station voltage may be unregulated, but the circuit must be capable of providing a minimum of 35mA (50mA for the 5844SHRT) continuously. Model 5844HRT has a ground stud (#6-32 bolt) and a power connector on the side of the case. If Model 5844HRT is powered through the power connector, then connect a suitable earth ground to the grounding stud on the side of the Link/Repeater. Remove the power plug from the power connector of the Link/Repeater. Connect the power lines to the power plug being careful not to leave any wire strands exposed.

This power input to the Model 5844HRT is Surge Withstand Protected to IEC 61000-4-4, EN61000-4-5 Standard and ANSI/IEEE C37.90.1-1989.

**NOTE**

**Model 5844HRT or Model 5844SHRT can be ordered to accommodate 24 Vdc - 48 Vdc power.**

**WARNING**

When installing a Model 5844HRT or a 5844SHRT Link/Repeater, an earth Ground must be attached to the Ground Stud on the side of the case before connecting to power. Failure to follow this procedure may result in electrical shock to personnel.

**1.2.11 Peripheral Equipment**

1.2.11.1 IED

An IED is any intelligent electrical device such as; a computer, RTU, PLC, "smart" meter, relay, etc., that has the ability to communicate data via RS-232 or TTL format. The IED should have a communication port for the connection of the Link/Repeater. If the IED's communication port connector does not accept the Link/Repeater to be plugged in directly, an adapter must be made to accommodate the connection. Care should be taken to assure

that the correct signals are connected to each other. See Figure 2 for the Link/Repeater's pin signal assignments. Check your IED's equipment manual for its signal assignments.

The IED must also have intelligent software to execute the data communication. This intelligence needs to logically manage the data and signal traffic, including any addressing, token passing, "handshaking", data formatting and scheduling.

#### 1.2.11.2 Fiber Optic Cable (FOC)

The selection of the fiber optic cable is important. High quality cable can assure the maximum performance of your Link/Repeater. Important factors to consider are the manufacturer's specification on attenuation per unit length, attenuation due to aging, diameter, and tensile strength. Choosing the best quality FOC for your installation is important.

#### NOTE

**DYMEC can supply multi-mode glass FOC in either Simplex, Duplex, or Breakout construction, cut to length, terminated, polished and tested. The specification for all DYMEC supplied cables are as follows:**

<b>Fiber Diameter:</b>	<b>62.5/125µm</b>
<b>Tensile Strength:</b>	<b>100 kpsi</b>
<b>Loss:</b>	<b>3 dB per kilometer</b>
<b>Aging Loss:</b>	<b>less than 3 dB</b>

Model 5843HRT and Model 5844HRT Link/Repeater optical ports are designed for ST type terminations and are compatible with multi-mode FOC ranging from 50 µm to 200 µm.

Model 5843SHRT and Model 5844SHRT Link/Repeater optical ports are designed for ST type terminations and are compatible with single-mode FOC ranging from 5 µm to 13 µm.

## 2. CONFIGURATIONS, OPERATION, AND INSTALLATION

Model 5843HRT and Model 5844HRT Link/Repeaters can be connected in a Point-to-Point configuration, in a Master/Slave Loop, in a Peer-to-Peer Loop or an optical bus depending on the needs of the overall communication system.

These models are designed to accept electrical inputs per RS-232 and TTL standards.

RS-232 data communication signals are always on pins 2 or 3 (transmit or receive pin assignment is based upon the setting of the DTE/DCE switch) of the Link/Repeater's 9 Pin D-connector.

For TTL data communication, the transmit (Link/Repeater receive) is on either pin 2 or 3 depending on the setting of the DTE/DCE switch and the receive (Link/Repeater transmit) is on pin 8.

When the Link/Repeater has a high TTL potential (above 2.4 volts) on its transmit pin, it will transmit optically.

All signal voltage levels on the 9 Pin D-connector are referenced to pin 5 of the D-connector.

### NOTE

**Pin 8 always has the TTL data output signal present even during RS-232 communication. Be sure that the presence of the TTL signal on pin 8 will not adversely affect the IED operation.**

It is also possible to optically connect Link/Repeaters together which are connected to IED's with different electrical formats. It is possible to optically interconnect Models 5845HRT and 5846HRT (operating EIA 422/485) to DYMEC Models 5843HRT and 5844HRT which are connected to IED's operating RS-232 or TTL formats.

### APPLICATION NOTE

**DYMEC Models 5843HRT, 5844HRT, 5845HRT and 5846HRT can optically communicate to each other, eliminating the need for format translation interfaces, provided all connected devices are operating at the same data rate.**

#### 2.1 POINT-TO-POINT CONFIGURATION

For Point-to-Point operation, two Link/Repeaters are optically connected to each other.

This configuration permits full duplex communication (simultaneous transmitting and receiving), half duplex communication (sequential transmitting and receiving), and simplex (transmitting or receiving only).

## APPLICATION NOTE

In Point-to-Point operation, the communication logic (control software) of the IED's must manage:

- 1) The transmission of data signals.
- 2) The receipt of data signals.
- 3) Any "handshaking" required must be accomplished through software.

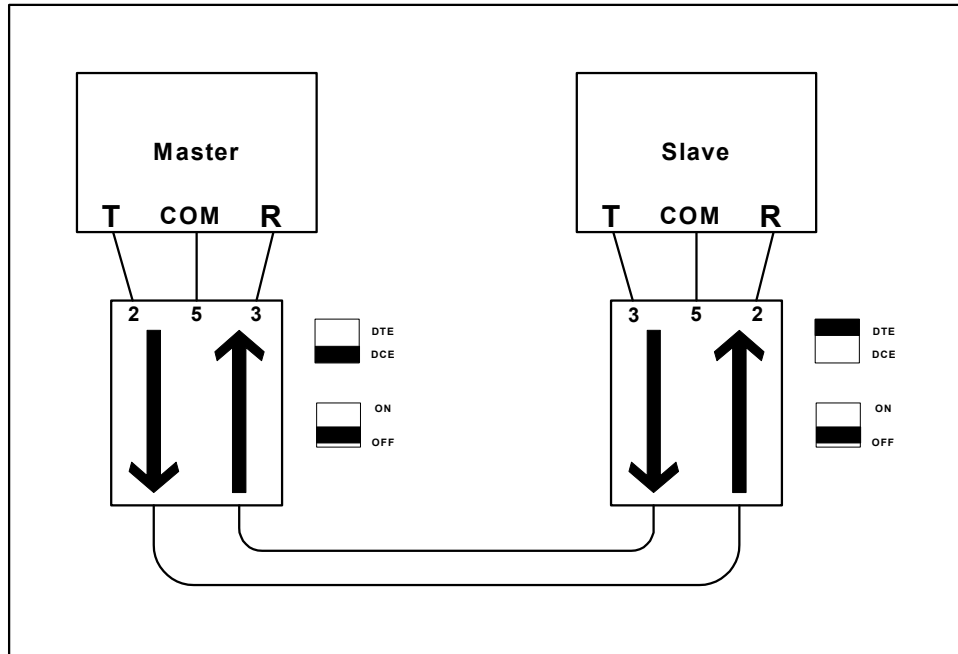

FIGURE 6. Point-to-Point Configuration

### 2.1.1 Installation

1. Set the DTE/DCE Switch to the appropriate position for each Link/Repeater and its respective IED.
2. Set the Repeat Switch on all of the units to the "OFF" position.
3. Connect the Link/Repeater to the IED's RS-232 or TTL communication port (including any adapter that may be needed).
4. Connect the Fiber Optic Cables (T of one device to R of the second device).
5. Connect power to the Link/Repeater as follows:
  - A) If the unit is to be powered through the D-connector (9 to 15 VDC on pin 9 referenced to pin 5), then the unit is energized when it is connected to the D-connector (the power LED will illuminate).
  - B) Connect power leads to the power connector and then energize the power source. The unit is now powered (the power LED will illuminate).

**WARNING**

When installing a Model 5844HRT or 5844SHRT Link/Repeater, an earth Ground must be attached to the Ground Stud on the side of the case before connecting to power. Failure to follow this procedure may result in electrical shock to personnel.

6. The units are now installed and operating.
7. Verify operation using the diagnostic LEDs. (See Figure 5).

**NOTE**

The LEDs only illuminate when there is signal traffic and are not illuminated during signal "quiet" times.

The LEDs may "flicker". This is normal operation.

**APPLICATION NOTE**

The Point-to-Point concept can be used to create an "optical bus" network. This can be useful for those situations where the software in the Master has not been written in such a way that it can handle the return of the transmitted echo that occurs in loop networks.

Figure 7 shows the connection scheme for an RS-232 optical bus. Note that all Slaves hear the Master's transmission but only the Master hears the response from the addressed Slave. The Master must always be the first IED in the network.

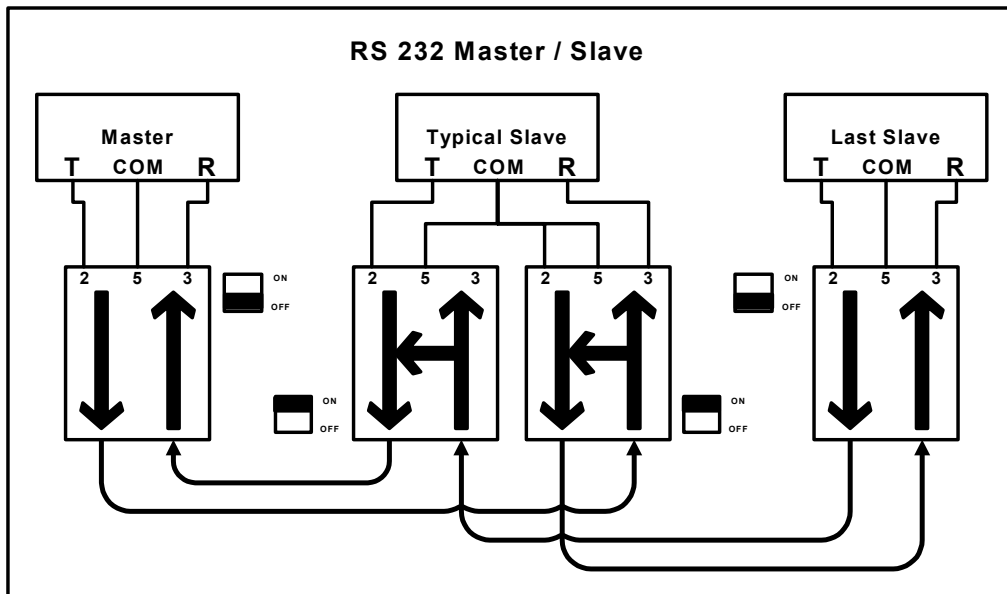

**FIGURE 7. RS-232 Bus Configuration**

## APPLICATION NOTE

**Another variation of the point-to-point concept, is the Optical Star network. This topology may be created using the Dymec Optical Star OS5 or OS9. This topology creates a “Hub and Spoke” configuration which can be useful in solving a network configuration based upon the physical positioning of the nodes.**

The Dymec Optical Stars can also be used to create a multi-drop Master / Slave Optical Star network. The Model 5843HRT and 5844HRT are optically compatible with the OS5 and OS9 Master and Slave ports. Figure 9 shows a typical connection of an Optical Star network.

The master IED must always be connected to the Master port of the Optical Star. The slave IED's must always be connected to the Slave ports of the Optical Star.

Variations of this configuration are as follows:

- The optical star may be the last node of an optical bus configuration. One may create an Optical Bus configuration starting with the Master IED to a series of Slave IED's and then connect the fiber network to the Master port of the OS5 or OS9 to continue the network in a “Hub and Spoke” topology.
- A Master IED may be connected to the master port of an OS5 or OS9 and then an Optical Bus network may be created from any Slave Port of the Optical Star.
- The Optical Stars maybe “cascaded”. Cascading means optically connecting a Slave Port of one Optical Star to the Master Port of the next Optical Star.
- IED's of different electrical formats (i.e., RS-232, EIA 422, EIA 485 2-wire or EIA 485 4-wire) may also be interconnected optically in the Star Configuration. Models 5845HRT and Models 5846HRT are optically compatible with the 5843HRT and 5846HRT and are used to serve to serve the EIA 422 and EIA 485 devices.

## NOTE

**It is not recommended that a “loop network” be connected to an Optical Stars Slave Port**

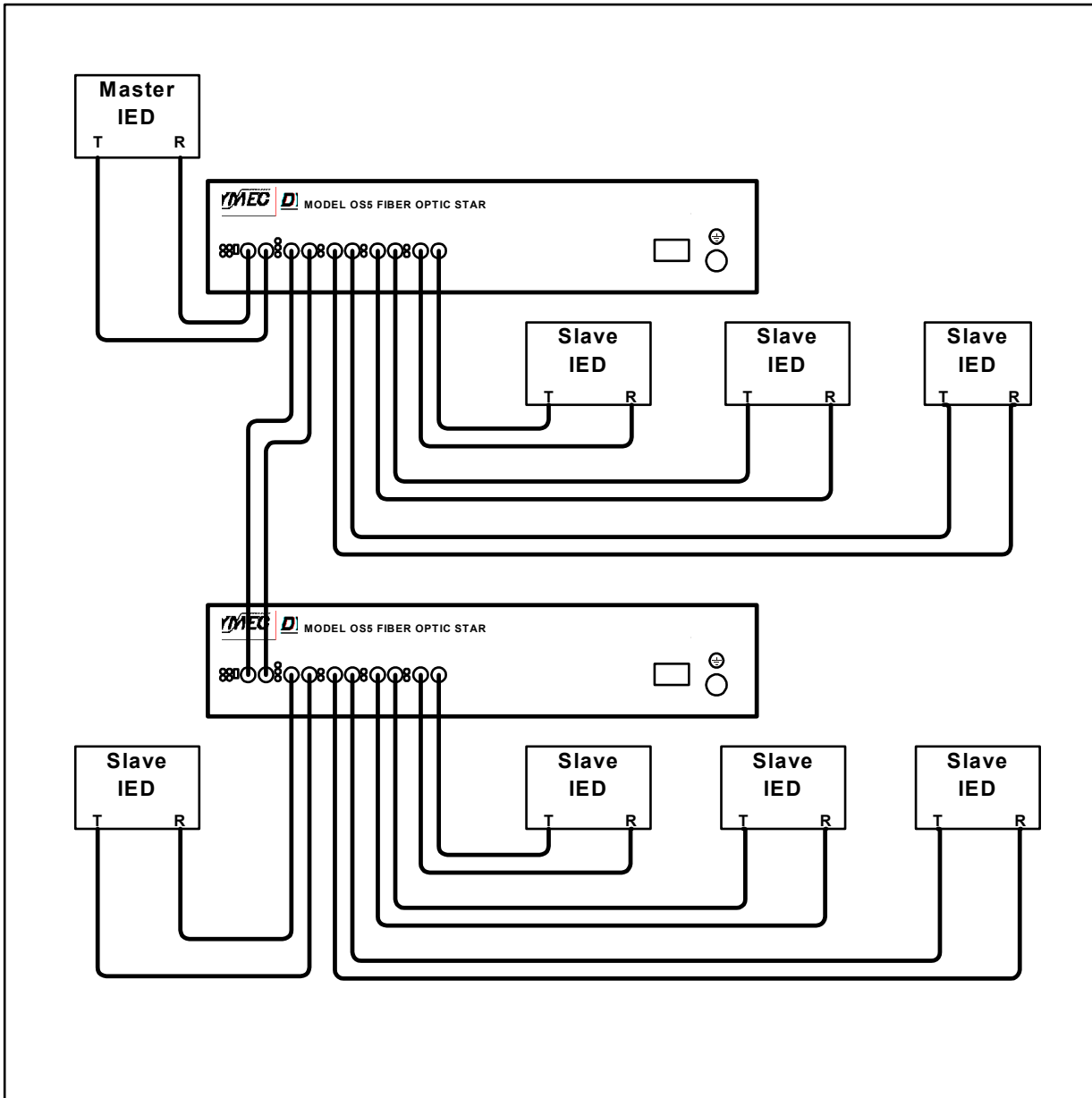

**FIGURE 9. Optical Star Configuration  
(OS5 cascaded to an OS5)**

## 2.2 LOOP OPERATION - MASTER/SLAVE CONFIGURATION

### NOTE

Before constructing a loop network, be sure that the software protocol of the Master is capable of managing the receipt of its own, echoed transmission. If it cannot, then use Point-to-Point configurations only between devices in an "optical bus" network approach.

This configuration supports a system that requires more than two IED's to be communicating. In a Master/Slave loop system, one IED acts as a Master at all times and addresses or "polls" each of the other connected IED's individually. Each Slave receives the same transmission from the Master IED but only responds when it recognizes its address in the polling message.

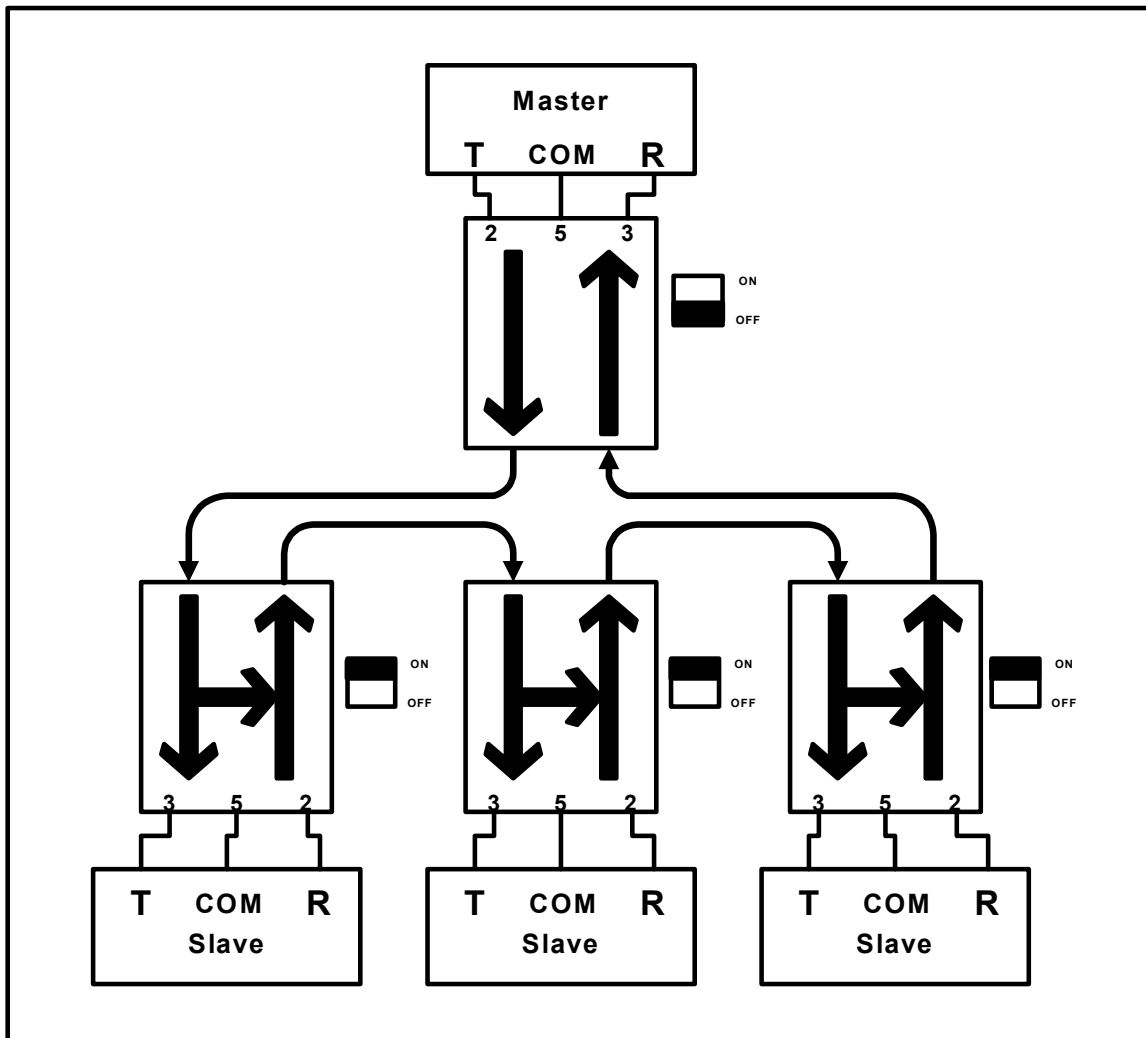

FIGURE 8. Master/Slave Loop Configuration

The Master must have its Repeat Switch in the "OFF" position. When it transmits a request out its T optical port, it will receive the echo of its request at its R optical port. This request has gone around the loop, and has been repeated by each Slave in the loop. However, the Master does not repeat (re-transmit) any of these received signals optically back around the loop, because its Repeat Switch is in the "OFF" position.

#### NOTE

**The communication logic and control software of the Master IED must be able to manage the receipt of its echoed request. The receipt of the echo can be used in conjunction with a watchdog timer to continuously verify loop integrity.**

When addressed, the Slave will transmit an appropriate response. Each Link/Repeater connected to a Slave IED must have its Repeat Switch set in the "ON" position. In this mode, all signals received on a Slave's R optical port are delivered to the IED's communication port and at the same time repeated out the T optical port to the next device in the loop. If an IED determines that this request requires a response, then the Link/Repeater transmits the IED's response out the T optical port. The response is repeated at each Slave device, until it arrives at the Master.

When an IED is a Slave, it should not attempt to initiate a transmission while it is receiving a signal. Since signals being received are also being repeated at the same time, any attempts to transmit its response while still receiving can corrupt both transmissions due to a data collision.

#### CAUTION

If a Slave IED attempts to transmit while receiving a message, a data collision will occur.

In Master/Slave Loop Operation, half duplex communication (sequential transmit and receive functions) is available. Only the Master can communicate full duplex (simultaneous transmit and receive) in a Master/Slave loop.

#### APPLICATION NOTE

**In a Master/Slave Loop Operation, the communication logic (control software) and the Master IED must manage:**

- 1) **The transmission to Slaves (including addressing).**
- 2) **The receipt of the echo of its transmissions.**
- 3) **The receipt of the Slave's response to its transmission.**
- 4) **The control of the Slaves to prevent the initiation of a transmission while receiving a signal.**

##### 2.2.1 Installation

1. Set the DTE/DCE Switch to the appropriate position for each Link/Repeater and its respective IED.
2. Set the Repeat Switch to the "OFF" position on the Master. Set the Repeat Switch to the "ON" position on each Slave.
3. Connect the Link/Repeater to the IED's RS-232 or TTL communication port (Including any adapter that may be needed).
4. Connect the Fiber Optic Cables (T of one device to R of the next device in the loop). Continue around the loop back to the Master to close the loop.

5. Connect power to the Link/Repeater as follows:
  - A) If the unit is to be powered through the D-connector (9 to 15 VDC on pin 9 referenced to pin 5), then the unit is energized when it is connected to the D-connector (the power LED will illuminate).
  - B) If the unit is to be powered through the power connector: Connect the power leads and the power connector and then energize the power source. The unit is now powered (the power LED will illuminate).

**WARNING**

When installing a Model 5844HRT or 5844SHRT Link/Repeater, an earth Ground must be attached to the Ground Stud on the face of the case before connecting to power. Failure to follow this procedure may result in electrical shock to personnel.

6. The units are now installed and operating.
7. Verify operation using the diagnostic LEDs. (See Figure 5).

**NOTE**

**The LEDs only illuminate when there is signal traffic and are not illuminated during signal "quiet" times.**

**The LEDs may "flicker". This is normal operation.**

### **2.3 LOOP OPERATION - PEER-TO-PEER CONFIGURATION**

**NOTE**

**Before constructing a loop network, be sure that the software protocol is capable of managing the receipt of the echo of its own transmission. If it cannot, then use Point-to-Point configurations only between devices in an "optical bus" network approach.**

A Peer-to-Peer loop configuration is similar to the Master/Slave loop configuration except that each IED in the loop is capable of Mastering the loop in a pseudo-Master/Slave loop. To achieve this, Models 5843HRT and 5844HRT provide an electrical means of controlling the "OFF/REP" function.

In this system, all Link/Repeaters are connected in a loop with their Repeat Switch in the "OFF" position. Each IED must be able to control pin 7 of the D-connector to enable and disable the "ON" function. When an IED applies a low potential (less than 0.6 Vdc to pin 7) it enables the repeat function of the Link/Repeaters. This is equivalent to the Repeat Switch being in the "ON" position. When an IED wishes to become the loop Master, it raises the potential on pin 7 to a high potential (greater than 2.0 Vdc). This disables the Link/Repeaters' repeat function as if the Repeat Switch were in the "OFF" position.

**NOTE**

The communication logic and control software of the Master IED must be able to manage the receipt of its echoed request. The receipt of the echo can be used in conjunction with a watchdog timer to continuously verify loop integrity.

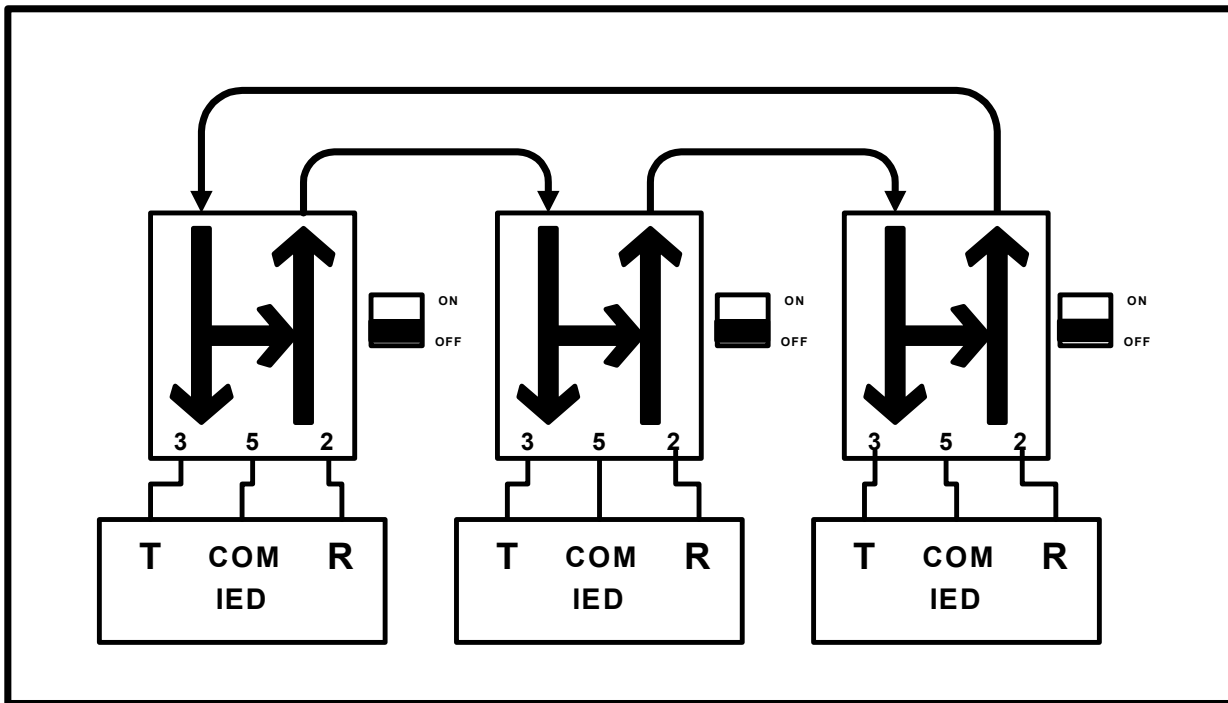

**FIGURE 9. Peer-to-Peer Loop Configuration**

When the potential on pin 7 is low, signals received on the R optical port are delivered to the IED and are repeated out the T optical port to the next device in the loop. A high potential on pin 7 causes signals received on the R optical port to be delivered to the IED only and are not repeated out the T port. It is not necessary for a Slave to raise the potential of its pin 7 to transmit.

After an IED has completed its tasks mastering the loop, it must return its pin 7 to a low potential enabling its repeater function, re-establishing loop continuity for the next IED that becomes loop Master.

**NOTE**

**Powering and Controlling pin 7 is ignored in all configurations except Peer-to-Peer loop operation.**

Half duplex communication is available with this configuration.

When an IED is in the Slave state, it should not attempt to initiate a transmission while it is receiving a signal. Since signals being received are also being repeated at the same time, any attempt to transmit its response while still receiving, can corrupt both transmissions due to a data collision.

**NOTE**

**Any Link/Repeater that has its Repeat Switch in the "OFF" position and has a high potential on pin 7 will not repeat signals received on its R optical port out of its T port. Only transmissions initiated by its IED are transmitted out its T optical port.**

## APPLICATION NOTE

In Peer-to-Peer loop operation, the communication logic (control software) and the Master IED must manage:

- 1) **The transmission to Slaves.**
- 2) **The receipt of the echo of its transmissions.**
- 3) **The receipt of the Slave's response to its transmission.**
- 4) **The control of pin 7 of D-connector.**
- 5) **The control of the Slaves to prevent the initiation of a transmission while receiving a signal.**

### 2.3.1 Installation

1. Set the DTE/DCE Switch to the appropriate position for each Link/Repeater and its respective IED.
2. Set the Repeat Switch on all the units to the "OFF" position.
3. Connect the Link/Repeater to the IED's RS-232 or TTL communication port (Including any adapter that may be needed).
4. Connect the Fiber Optic Cables (T of one device to R of the second device). Continue around the loop to complete the loop.
5. Connect power to the Link/Repeater as follows:
  - A) If the unit is to be powered through the D-connector (9 to 15 VDC on pin 9 referenced to pin 5), then the unit is energized when it is connected to the D-connector (the power LED will illuminate).
  - B) If the unit is to be powered through power connector or power connector: Connect the power leads and the power connector and then energize the power source. The unit is now powered (the power LED will illuminate).

#### WARNING

When installing a Model 5844HRT or 5844SHRT Link/Repeater, an earth Ground must be attached to the Ground Stud on the side of the case before connecting to power. Failure to follow this procedure may result in electrical shock to personnel.

6. The units are now installed and operating.
7. Verify operation using the diagnostic LEDs. (See Figure 5).

#### NOTE

**The LEDs only illuminate when there is signal traffic and are not illuminated during signal "quiet" times. The LEDs may "flicker". This is normal operation.**

### 3. APPLICATIONS

When planning a system using Model 5843HRT and Model 5844HRT Link/Repeaters, the following considerations should be reviewed:

- Data Rate
- Optical Budget and the distance between connected units
- Number of units in a loop configuration
- Powering the Link/Repeaters
- Type of communication including format
- Selection of Fiber Optic Cable (FOC)

#### 3.1 DATA RATE

Model 5843HRT and Model 5844HRT Link/Repeaters automatically support all data rates from 1200 bits per second (AC Coupled Factory Default) to 250 Kilobits per second. No internal selection nor setting is required. However, it is necessary that all connected IED's be set at the same data rate.

#### 3.2 OPTICAL BUDGET

The optical budget is a ratio of the receiver sensitivity to launched optical power, i.e. amount of light loss available from the transmitter to the receiver. It is calculated on a log scale so that a 3 dB loss is equal to half of the original power, 10 dB is one tenth of the original power, 20 dB is one hundredth, etc. Many different elements in the optical circuit can induce losses to the power of the signal. This attenuation must be taken into account when determining the distance that the signal can be transmitted. The major factor is the attenuation of the fiber optic cable. Cable attenuation is expressed as "X" dB per kilometer. Other factors of attenuation include FOC fittings (terminations, splitters, etc.) FOC diameter, and FOC aging.

Optical budget is the result of the expression:

$$\text{Optical Budget [dB]} = 10 \times \log_{10} \frac{\text{Receiver sensitivity } [\mu\text{W}]}{\text{Launch Power } [\mu\text{W}]}$$

Each Model 5843HRT or 5844HRT Link/Repeater has a typical optical budget of 19.5 dB.

Each Model 5843SHRT or 5844SHRT Link/Repeater has a typical optical budget of 19 dB.

##### 3.2.1 Cable Attenuation Factors

The following cable factors must be applied as corrections to the optical budget.

###### 3.2.1.1 Diameter

###### Multi-mode:

FOC of different diameters will vary the available optical budget of a system due to different FOC core diameters. The 19.5 dB typical optical budget is applicable to 62.5µm diameter FOC. Table 1 shows the correction factors to use on the available optical budget for different diameter cable.

Table 1

FOC Diameter	Factor
50µm	-3 dB
100µm	+4 dB
200µm	+7 dB

Single-mode:

19 dB of optical budget is typically available and is essentially consistent for fiber diameters.

3.2.1.2 Fittings

Adding additional splices, feed throughs, or patches to the FOC will add losses to the available optical budget. When using multi-mode Fiber Optic Cable terminated and supplied by DYMEC, optical connector losses can be ignored because the cable is tested after the terminations are added. If you are using fittings not supplied by DYMEC, you can get the optical budget loss information from their manufacturer(s).

3.2.1.3 Aging

As FOC ages, tiny cracks will form in the glass core of the fiber. These will cause the attenuation of the cable to increase. The optical emitters age over time causing a reduction in their optical launch power.

DYMEC suggests that a buffer be applied to the optical budget to assure proper operation of the unit over a 20-year life. A 2.5 dB to 3 dB loss factor is suggested to compensate for system aging over 20 years.

**EXAMPLE:**

*FOC is 62.5/125  $\mu$ m multi-mode (DYMEC supplied)  
100 kpsi rated 3 dB/km and 3 dB for aging  
No other attenuating items in the circuit*

<i>initial:</i>	<i>19.5 dB Optical Budget</i>
<i>less:</i>	<i>3 dB aging</i>
<i>less:</i>	<i>0 dB for other circuit attenuation fittings</i>
<i>equals:</i>	<i>16.5 dB</i>
<i>divided by:</i>	<i>3 dB/km</i>
<i>equals:</i>	<i>5.5 km maximum distance of FOC between transmitter and receiver</i>

**NOTE**

**FOC extends communication beyond normal RS-232 or TTL Standards limits. The distance allowable between Link/Repeaters must be calculated using the factors listed above.**

**3.2.2 Extending the Distance**

Should the distance between two devices exceed that calculated above, it is possible to insert a Model 5843HRT or Model 5844HRT Link/Repeater to function as a stand alone repeater, not connected to an IED. Two Link/Repeaters would be necessary, one for each fiber path. When installed as a repeater only, the 9 Pin D-connector of either Model 5843HRT or Model 5844HRT should be installed with a terminator that covers the pins and connects the transmit pin (2 or 3 - depending on the DTE/DCE switch position) to the signal common pin 5 and also connects the signal common pin 5 to the chassis ground pin 1.

### 3.3 NUMBER OF REPEATS

In a loop configuration, the number of units that can be used as repeaters must be determined. A repeater is any unit that uses the repeat function of the Link/Repeater. All Slaves in a Master/Slave loop are considered repeaters. Three factors must be considered in calculating the maximum number of repeaters possible in a loop; the data rate (bits per second), the minimum required width of the original pulse echoed back to the Master, and the peak operating temperature.

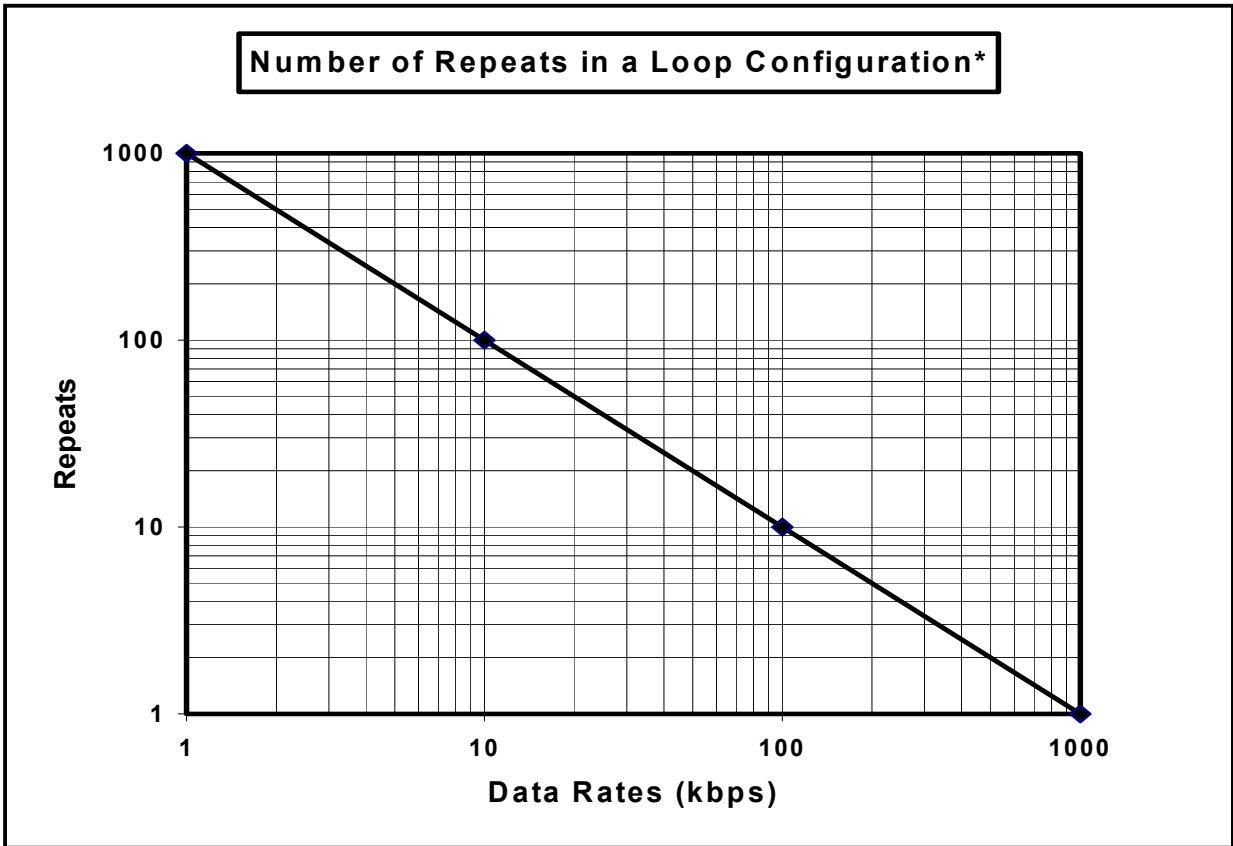

FIGURE 10. Number of Repeats

#### 3.3.1 Effects of Data Rate

The number of repeaters is an inverse linear function to the data rate (more repeats at lower data rates). The data rate, or bits per second rate, determines what the original pulse width of each bit will be. The higher the data rate, the smaller the pulse width of each bit. As the signal passes through a repeater, any distortion effect on the data signal is greater at higher data rates due to smaller pulse widths than lower data rates.

#### 3.3.2 Pulse Width Distortion

As the data signal is passed from repeater to repeater, there is a small change to the pulse width defined as pulse width distortion. The amount of change that is tolerable corresponds to the percentage of original pulse width required by a particular communication system design. Typically, a communication system requires the data word, or bit stream, that each Slave IED receives, match the signal originally generated by the Master, within some tolerance of pulse width distortion. High tolerance systems allow more pulse width distortion, therefore, more repeats are tolerated. Conversely, low tolerance systems allow fewer repeats in the loop.

Figure 10 shows the maximum number of repeats possible if 70% of the original pulse width is required by any IED in the loop. The acceptable percentage of the original pulse width is due to the requirements of the IED's. If more of the original pulse width is necessary or less is allowable, then the number found in Figure 10 can be modified. Table 2 shows the factors to be used to correct the number of repeats found in Figure 10 for such cases.

Table 2

% of Original Pulse	Multiply Factor
80%	.67
60%	1.33
50%	1.67

### 3.3.3 Temperature Effect

At peak operating temperature above 65°C, the maximum number of repeats should be de-rated by 20%. At higher temperatures, the distortion caused by each repeat increases, causing the maximum number of possible repeaters to go down.

**EXAMPLE:**

*Peak temperature of the system will be 70°C  
Running at 9600 bps  
60% of original pulse width possible*

*initial: 100 repeats (from Figure 10)  
less: 20% de-rate for 70°C  
times: 1.33 for 60% pulse width  
equals:  $100 \times 0.8 \times 1.33 = 106$  repeats*

## 3.4 POWERING THE LINK/REPEATER

### 3.4.1 Model 5843HRT

Model 5843HRT may be powered through pin 9 on the D-connector or by means of the 3.5 mm female connector located between its two optical ports. The unit has an input voltage range of 9 to 15 Vdc and requires a maximum of 250 mA (340mA for the 5843SHRT) over the entire operating temperature range. DYMEC's Model 4310S ac to dc power adapter is designed specifically for this purpose. It connects directly into a normal 110 volt power receptacle and has an operating temperature range of -0°C to +70°C.

### 3.4.2 Model 5844HRT

Model 5844HRT is designed with an internal universal regulated power supply for environments where unregulated ac or dc voltages are available. It accepts ac voltages in a range of 90 to 250 volts, 50 or 60 hertz, or dc voltages in a range of 90 to 250 volts. These power sources must be capable of supplying 35 mA (50mA for the 5844SHRT) over the entire operating range. It is also possible to power the Model 5844HRT through pin 9 on the D-connector.

## NOTE

The Model 5844HRT or Model 5844SHRT can be ordered to accommodate 24 Vdc to 48 Vdc power.

Model 5844HRT is provided with a ground stud on the side of the case. An appropriate earth ground must be connected to this stud before power is applied to the unit. The internal surge-withstand protection inside of the unit uses this ground stud as a sink for power surges. If the unit is not properly grounded, it may store a charge until a path to ground becomes available. The lowest impedance to ground is recommended to avoid a ground potential rise.

### WARNING

When installing a Model 5844HRT or Model 5844SHRT Link/Repeater, an earth Ground must be attached to the Ground Stud on the side of the case before connecting to power. Failure to follow this procedure may result in electrical shock to personnel.

### 3.5 OPTIONAL STATION POWER VOLTAGES

Models 5844HRT and 5844SHRT can be ordered to be powered by 24 to 48 Vdc. This modification is indicated by the suffix -L added to the Model number (i.e. 5844HRT-L). When ordered with either of these options, the unit has that DC voltage rating only and is Surge Withstand Protected to IEC 61000-4-4, EN61000-4-5 Standard and ANSI IEEE C37.90.1 - 1989.

### 3.6 TYPE OF COMMUNICATION

Model 5843HRT and Model 5844HRT Link/Repeaters support the following types of asynchronous communications:

- Simplex - Transmission only or receive only
- Half Duplex - Sequential transmit and receive
- Full Duplex - Simultaneous transmit and receive

	Simplex	Half Duplex	Full Duplex
Point-to-Point: (Repeat Switch "OFF")	X	X	X
Master/Slave Loop: Master (Repeat Switch OFF)	X	X	X
Master/Slave Loop Slave (Repeat Switch "ON")	X	X	
Peer-to-Peer Loop: Master (Repeat Switch "OFF" and pin 7 "high")	X	X	X
Peer-to-Peer Loop: Slave (Repeat Switch "OFF" and pin 7 "low")	X	X	

### 3.7 SELECTION OF FIBER OPTIC CABLE (FOC)

Fiber optical cable is available in several formats; simplex, duplex, and breakout. FOC is also available in various diameters and tensile strengths. Tensile strength is important for longer life expectancy.

**Simplex FOC** is desirable for loop operations. It has one optical conductor and can be connected from the transmitter of one Link/Repeater to the receiver of the next Link/Repeater in the loop.

**Duplex FOC** has two optical conductors and is a convenient form when connecting two units Point-to-Point.

**Breakout cable** is a duplex FOC that has extra strength members added and is suitable for burial.

The following are the specifications of multi-mode FOC offered by DYMEC and is the recommended minimum standard for optimum performance.

		<u>Simplex</u>	<u>Duplex</u>	<u>Breakout</u>
Fiber Count		1	2	2
Fiber Material		Glass	Glass	Glass
Attenuation	[dB/km]	3	3	3
Diameter	[mm]	3.0	3.0 x 6.5	7.0
Weight	[kg/km]	8.0	16.0	50
Tensile load - Short Term	[N]	500	1000	1200
Tensile load - Long Term	[N]	300	500	500
Minimum Bend Radius - With Load	[cm]	5	5	14
Minimum Bend Radius - No Load	[cm]	3	3	7
Crush Resistance	[N/cm]	750	750	2200
Impact Resistance	[Cycles]	1000	1000	2500
Flex Resistance	[Cycles]	7500	7500	2000
Operating Temperature	[°C]	-40° to +85°	-40° to +85°	-40° to +85°
Storage Temperature	[°C]	-55° to +85°	-55° to +85°	-55° to +85°

#### METRIC-TO-ENGLISH UNIT CONVERSIONS

		<u>MULTIPLY</u> <u>BY</u>			<u>MULTIPLY</u> <u>BY</u>
Millimeters	→ Inches	0.03937	Kilograms	→ Pounds	2.2046
Centimeters	→ Inches	0.3937	Kg/Km	→ Pounds/1,000 Ft	0.67197
Meters	→ Feet	3.2808	Newtons	→ Pounds	0.22481
Kilometers	→ Feet	3280.8	N/Cm	→ Pounds/inch	0.57101
Kilometers	→ Miles	0.62137			

## 4. TESTING AND TROUBLESHOOTING

### 4.1 TESTING

Models 5843HRT and 5844HRT lend themselves to easy installation and testing. Testing the units requires transmitting and receiving data or setting the Test Mode switch to ON while observing that the diagnostic LEDs are illuminating in the proper sequence.

To test whether a unit is transmitting and receiving correctly, insert a short fiber jumper between its T and R optical ports, transmit a signal (or turn the Test Mode Switch ON) and note that all four diagnostic LEDs should illuminate during communication (refer to Figure 5).

To test the units in a loop configuration, two Link/Repeaters are required. Connect short Fiber jumper from the T optical port of one Link/Repeater to the R optical port of the other. Set the Repeat Switch for one of the units to ON and the other to OFF. The unit with the Repeat Switch in the OFF position is the Master. Using the Master, transmit and receive (or use the Test Mode Switch in the ON position) through the other unit in the repeat mode. Observe that the diagnostic LEDs illuminate during communication (refer to Figure 5).

When a Link/Repeater is not connected to an IED and is in the "repeat" mode, Transmit (pin 2 or pin 3) depending on the position of the DCE/DTE switch) and Chassis Ground (pin 1) should be connected to Signal Common (pin 5). This will prevent any spurious noise from being induced into the fiber optic loop circuit while servicing an IED.

#### Models 5843SHRT and 5844SHRT (only)

When not connected to an IED and in the repeat mode, the Link/Repeater should have Chassis Ground (pin 1) connected to Signal Common (pin 5). If these pins are not tied together, noise could be induced into the fiber loop. This is also necessary when servicing an IED in order to keep the fiber loop and the Link/Repeater operational.

#### **WARNING**

The jumper connecting Chassis Ground and Signal Common should be disconnected before reconnecting Models 5843SHRT or 5844SHRT to an IED.

### 4.2 TROUBLESHOOTING

If the unit does not work properly, use the following check list:

- Is the unit properly powered?
  - 1) Verify the unit is receiving the correct power.
  - 2) Is the Power LED on.
  - 2) If required, make sure power from D-connector is on Pin 9.
- Check that the diagnostic LEDs are responding to the optical and electrical activity.
- Is the unit mated properly to the IED? If an adapter is used, check that pin assignments are connected correctly.
  - 1) Are the fiber cables connected properly? T to R; not R to R nor T to T.
  - 2) Is the DTE/DCE switch and the Repeat switch set to the proper positions for the application?

Models 5843, 5844, 5843S and 5844S  
RS-232 or TTL

- Determine that the IED's originating signal is within standards.

**NOTE**

**If the Link/Repeater is not connected directly to an IED, determine that the electrical signal received by the Link/Repeater is not corrupt. The Link/Repeater only repeats the signal it is given, it does not re-clock or re-generate the signal.**

- Review the IED's software and protocols. Does the IED have physical "handshaking" requirements and have the appropriate settings on the IED been made to compensate for these requirements?
- Consult factory.

**NOTE**

**The LEDs only illuminate when there is signal traffic and are not illuminated during signal "quiet" times. The LEDs may "flicker". This is normal operation.**

**NOTE**

**Link/Repeaters contain no serviceable parts. Opening the unit will void the warranty.**

**5. SPECIFICATIONS**

**5.1 Electrical and Optical Specifications** (All Specifications over entire Operating Temperature Range)

**Multimode**

**5843HRT**

**5844HRT**

Optical Budget Typical	19.5 dB	19.5 dB
Output power Typical	-10.5 dBm peak	-10.5 dBm peak
Receiver Sensitivity Typical	-30 dBm peak (62.5/125 Multimode)	-30 dBm peak (62.5/125 Multimode)
Wavelength	850nm	850nm
Connector Type	ST	ST
Compatible Fiber Type	Multimode (50-200µm)	Multimode (50-200µm)
Configuration (Switches)	DTE/DCE AC/DC Coupled Link/Repeat	DTE/DCE AC/DC Coupled Link/Repeat
	Pin 8 Drive Current	Pin 8 Drive Current
	Pin 6 +5 V (DSR or CTS pull-up)	Pin 6 +5 V (DSR or CTS pull-up)
	Diagnostic Mode	Diagnostic Mode
Data Rate	DC to 250K bps	DC to 250K bps
Data Transmission	Asynchronous, simplex or Full Duplex	Asynchronous, simplex or Full Duplex
Transmission Distance	up to 5000 meters (62.5/125 Cable@3dB/km)	up to 5000 meters (62.5/125 Cable@3dB/km)
Bit Error Rate	10-E9 Max.	10-E9 Max.
Point to Point Latency	4 µsec Max	4 µsec Max
Repeat Latency	400 nsec Max	400 nsec Max

**Electrical Parameters**

**Inputs**

I/O Data Format	EIA RS232; CCITT v24	EIA RS232; CCITT v24
Data Connector	9 pin D-Type Female	9 pin D-Type Female
Input Impedance	>3000Ohms	>3000Ohms
Input Voltage	+/- 30 Volts Max	+/- 30 Volts Max

**Outputs**

Output Impedance	>300 Ohms	>300 Ohms
Driver Output	+/- 5 V min into 3000 Ohms	+/- 5 V min into 3000 Ohms
Pin 8 Output	0 to 5V	0 to 5V
	67 or 207 Ohm	67 or 207 Ohm
	Source Impedance	Source Impedance

**Ambient Temperature**

Operating Temperatures	-40 to +85 C	-40 to +85 C
Storage Temperature	-40 to +85 C	-40 to +85 C
Power Required	3.0 Watts 250 mA @ 12V	4.0 Watts 35 mA @ 90-250 V (-H) 250 mA @ 24-48 V (-L)
Power Dissipation BTU/H	8.2 BTU	10.9 BTU
Weight	9 Ozs.	17 Ozs.
Dimensions Inches	2.0W X 5.1L X 1.3H	4.1W X 5.1L X 1.3H
Indicators	Power Transmit Fiber Transmit Electrical Receive Fiber Receive Electrical	Power Transmit Fiber Transmit Electrical Receive Fiber Receive Electrical

**All Specifications are subject to change without notice.**

**Single-mode**

Optical Budget Typical  
 Output power Typical  
 Receiver Sensitivity Typical

Wavelength  
 Connector Type  
 Compatible Fiber Type  
 Configuration (Switches)

Data Rate  
 Data Transmission

Transmission Distance

Bit Error Rate  
 Point to Point Latency  
 Repeat Latency

**Electrical Parameters****Inputs**

I/O Data Format  
 Data Connector  
 Input Impedance  
 Input Voltage

**Outputs**

Output Impedance  
 Driver Output  
 Pin 8 Output

**Ambient Temperature**

Operating Temperatures  
 Storage Temperature  
 Power Required

Power Dissipation BTU/H  
 Weight  
 Dimensions Inches  
 Indicators

**5843SHRT**

19 dB  
 -14.5 dBm peak  
 -33.5 dBm peak  
 (9/125 Single-Mode)  
 1300nm  
 ST  
 Single-Mode (9-13µm)  
 DTE/DCE  
 AC/DC Coupled  
 Link/Repeat  
 Pin 8 Drive Current  
 Pin 6 +5 V (DSR or CTS pull-up)  
 Diagnostic Mode

DC to 250K bps  
 Asynchronous, simplex  
 or Full Duplex  
 up to ~30K meters  
 (9/125 Cable@0.3dB/km)

10-E9 Max.  
 4 µsec Max  
 400 nsec Max

EIA RS232; CCITT v24  
 9 pin D-Type Female  
 >3000Ohms  
 +/- 30 Volts Max

>300 Ohms  
 +/- 5 V min into 3000 Ohms  
 0 to 5V  
 67 or 207 Ohm Source Impedance

-40 to +70 C  
 -40 to +85 C  
 4.1 Watts  
 340 mA @ 12V

10.2 BTU  
 9 Ozs.  
 2.0W X 5.1L X 1.3H  
 Power  
 Transmit Fiber  
 Transmit Electrical  
 Receive Fiber  
 Receive Electrical

**5844SHRT**

19 dB  
 -14.5 dBm peak  
 -33.5 dBm peak  
 (9/125 Single-Mode)  
 1300nm  
 ST  
 Single-Mode (9-13µm)  
 DTE/DCE  
 AC/DC Coupled  
 Link/Repeat  
 Pin 8 Drive Current  
 Pin 6 +5 V (DSR or CTS pull-up)  
 Diagnostic Mode

DC to 250K bps  
 Asynchronous, simplex  
 or Full Duplex  
 up to ~30K meters  
 (9/125 Cable@0.3dB/km)

10-E9 Max.  
 4 µsec Max  
 400 nsec Max

EIA RS232; CCITT v24  
 9 pin D-Type Female  
 >3000Ohms  
 +/- 30 Volts Max

>300 Ohms  
 +/- 5 V min into 3000 Ohms  
 0 to 5V  
 67 or 207 Ohm  
 Source Impedance

-40 to +70 C  
 -40 to +85 C  
 5.5 Watts  
 50 mA @ 90-250 V (-H)  
 340 mA @ 18-60 V (-L)

12.3 BTU  
 17 Ozs.  
 4.1W X 5.1L X 1.3H  
 Power  
 Transmit Fiber  
 Transmit Electrical  
 Receive Fiber  
 Receive Electrical

## 5.2 Mechanical Dimensions of the 5843HRT and 5843SHRT

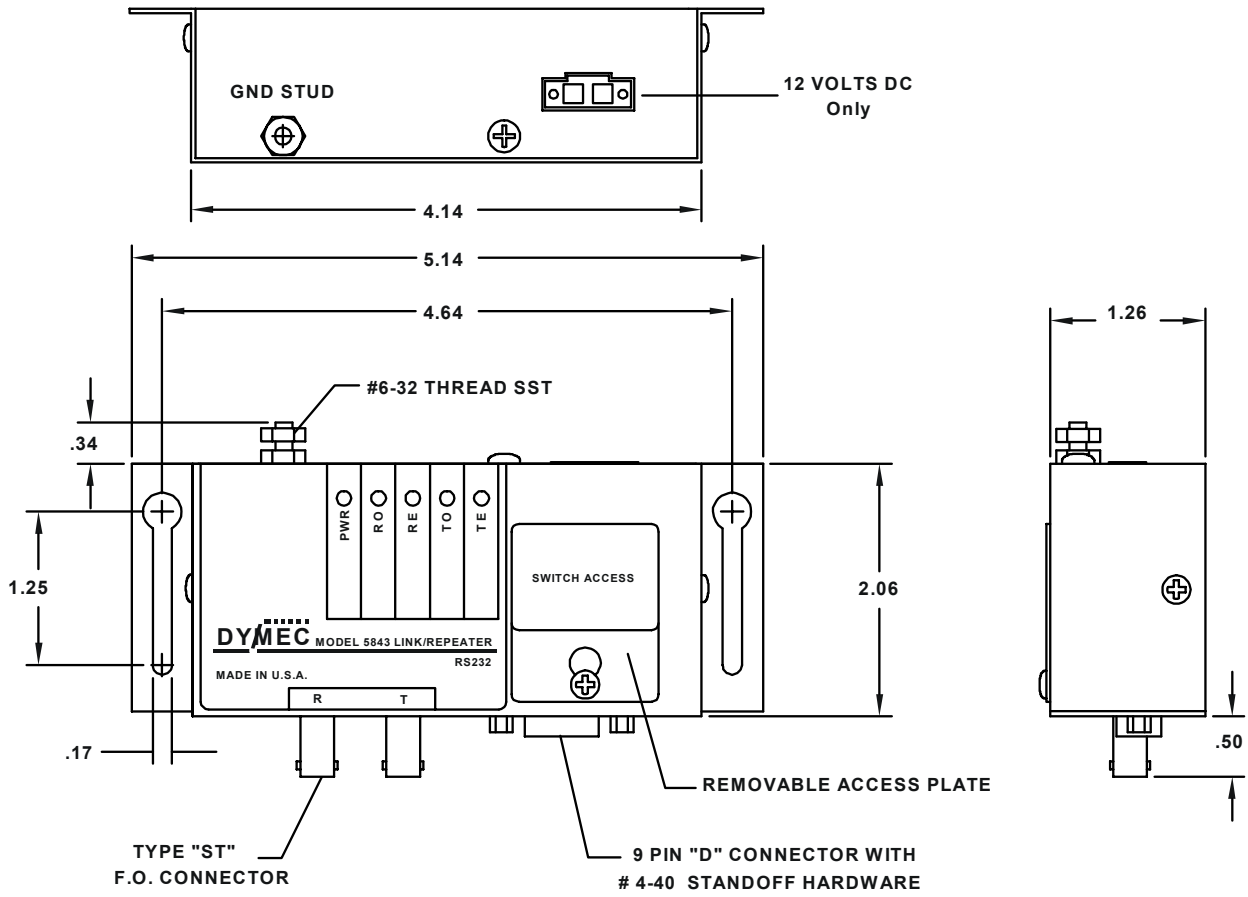

**NOTE: DIMENSIONS ARE IN INCHES.**

### 5.3 Mechanical Dimensions of the 5844HRT and 5844SHRT

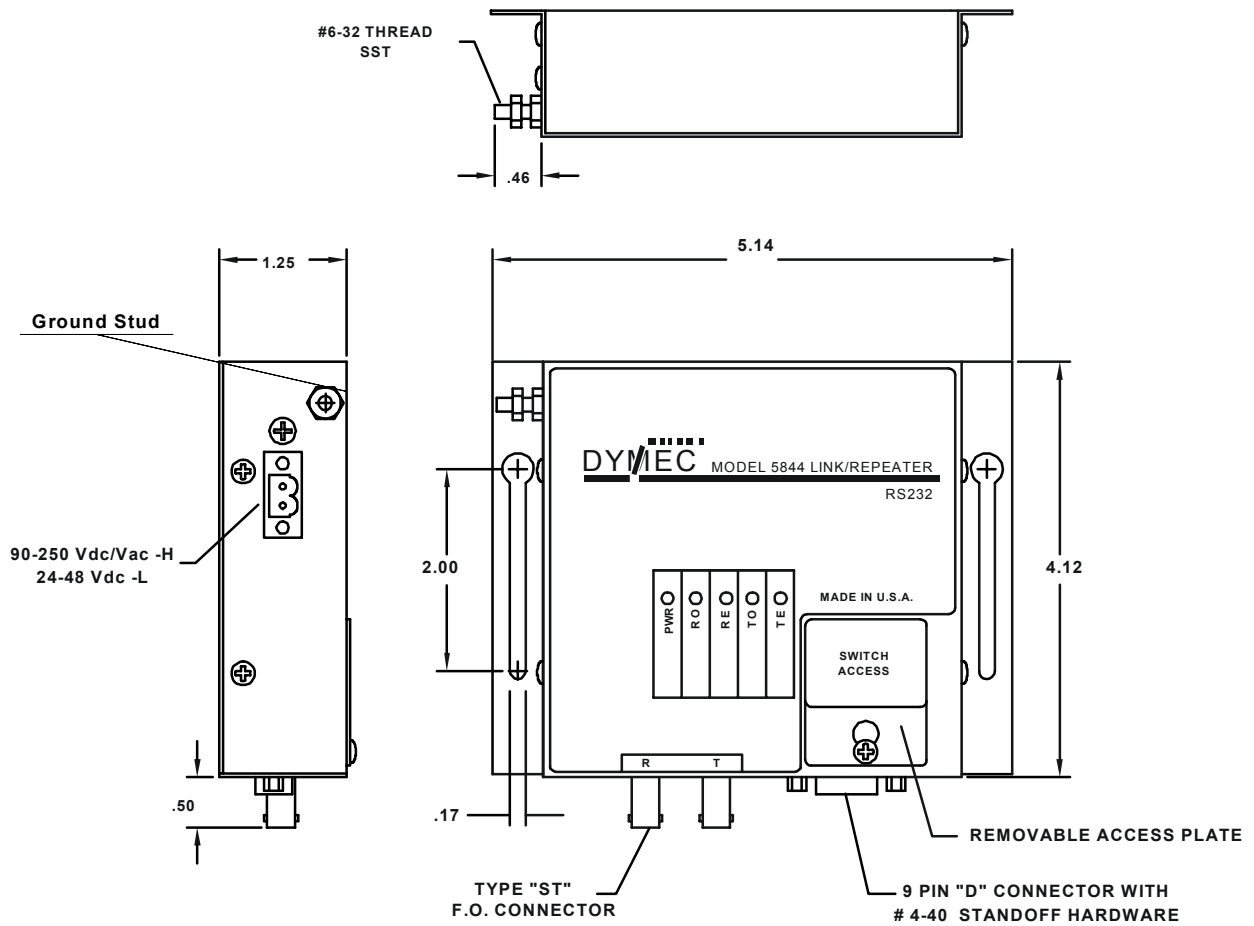

## 6.0 Ordering Information:

### LINK/REPEATERS

Part Number			
Model	EIA Std	Fiber Type	Input Power Rating
5843HRT	RS-232/TTL	Multi-Mode	12 Vdc
5844HRT-H	RS-232/TTL	Multi-Mode	90-250 Vdc/ 90-250 Vac
5844HRT-L	RS-232/TTL	Multi-Mode	24-48 Vdc
5845HRT	EIA 422/485	Multi-Mode	12 Vdc
5846HRT-H	EIA 422/485	Multi-Mode	90-250 Vdc/ 90-250 Vac
5846HRT-L	EIA 422/485	Multi-Mode	24-48 Vdc
5843SHRT	RS-232/TTL	Single-Mode	12 Vdc
5844SHRT-H	RS-232/TTL	Single-Mode	90-250 Vdc/ 90-250 Vac
5844SHRT-L	RS-232/TTL	Single-Mode	24-48 Vdc
5845SHRT	EIA 422/485	Single-Mode	12 Vdc
5846SHRT-H	EIA 422/485	Single-Mode	90-250 Vdc/ 90-250 Vac
5846SHRT-L	EIA 422/485	Single-Mode	24-48 Vdc

### ACCESSORIES

Model	Description
4310	AC to 12 Vdc Power adapter for Models 5843HRT and 5845
4310S	AC to 12 Vdc Power adapter for Models 5843SHRT and 5845S
ACC-CBL1	DB9 Male/Tinned Lead 10Foot Cable/Pigtail
ACC-LCS	Link Cantilever Shelf
Bulletin UM5843	User Manual for Models 5843, 5843S, 5844 and 5844S
Bulletin UM5845	User Manual for Models 5845, 5845S, 5846 and 5846S
5753A-XXXX	Simplex Multi-Mode Fiber Optic Cable (62.5/125 $\mu$ m), 100 KPSI. Suitable for use in cable troughs, conduit, and outdoor applications.
5754A-XXXX	Duplex Multi-Mode Fiber Optic Cable (62.5/125 $\mu$ m), 100 KPSI. Suitable for use in cable troughs, conduit, and outdoor applications.
5756A-XXXX	Breakout Duplex Multi-Mode Fiber Optic Cable (62.5/125 $\mu$ m), 100 KPSI. Suitable for use in cable troughs, conduit, and outdoor applications and direct burial, underground burial, lashed and building riser.
Terminations	Cable cut to length, Terminated with ST Type Multi-Mode Fiber Optic Connector and Complete Assembly Tested

XXXX = the length of the fiber optic cable in Meters (note: order only in full meters and not a fraction thereof) 1 Meter = 3.281 Feet

*READER'S COMMENTS*

**We invite your comments and welcome suggestions to make this manual more useful.**

Bulletin # \_\_\_\_\_ Rev # \_\_\_\_\_ Today's Date \_\_\_\_\_

**GENERAL COMMENTS:**

	<b>Improve</b>	<b>Acceptable</b>	<b>Good</b>	<b>Excellent</b>
Contents	<input type="checkbox"/>	<input type="checkbox"/>	<input type="checkbox"/>	<input type="checkbox"/>
Organization	<input type="checkbox"/>	<input type="checkbox"/>	<input type="checkbox"/>	<input type="checkbox"/>
Accuracy	<input type="checkbox"/>	<input type="checkbox"/>	<input type="checkbox"/>	<input type="checkbox"/>
Clarity	<input type="checkbox"/>	<input type="checkbox"/>	<input type="checkbox"/>	<input type="checkbox"/>
Completeness	<input type="checkbox"/>	<input type="checkbox"/>	<input type="checkbox"/>	<input type="checkbox"/>
Example/Illustrations	<input type="checkbox"/>	<input type="checkbox"/>	<input type="checkbox"/>	<input type="checkbox"/>
Referencing/Indexing	<input type="checkbox"/>	<input type="checkbox"/>	<input type="checkbox"/>	<input type="checkbox"/>
Readability	<input type="checkbox"/>	<input type="checkbox"/>	<input type="checkbox"/>	<input type="checkbox"/>

**DETAILED COMMENTS:** (Please be specific; i.e.: correct, expand, etc. )

**Page No.      Comments**

Other suggestions for improving this document: \_\_\_\_\_  
 \_\_\_\_\_

Compared to other manufacturers of a similar product, how would you rate this document?

Superior	Comparable	Inferior	Don't Know
<input type="checkbox"/>	<input type="checkbox"/>	<input type="checkbox"/>	<input type="checkbox"/>

Comments: \_\_\_\_\_  
 \_\_\_\_\_

Comments concerning your specific application: \_\_\_\_\_  
 \_\_\_\_\_

Name: \_\_\_\_\_  
 Title: \_\_\_\_\_  
 Company: \_\_\_\_\_  
 Address: \_\_\_\_\_  
 City/State/Zip: \_\_\_\_\_  
 Telephone/FAX: \_\_\_\_\_

**Please FAX or mail this sheet to the address listed below. Attn: Document Supervisor**



25 Commerce Way #1 North Andover, MA 01845  
 (978) 688-8807 • FAX (978) 688-8771  
**www.dymec.com**